

HAGUE

HYDRO-CLEAN III



INSTALLATION AND SERVICE MANUAL

VERSION 1.0

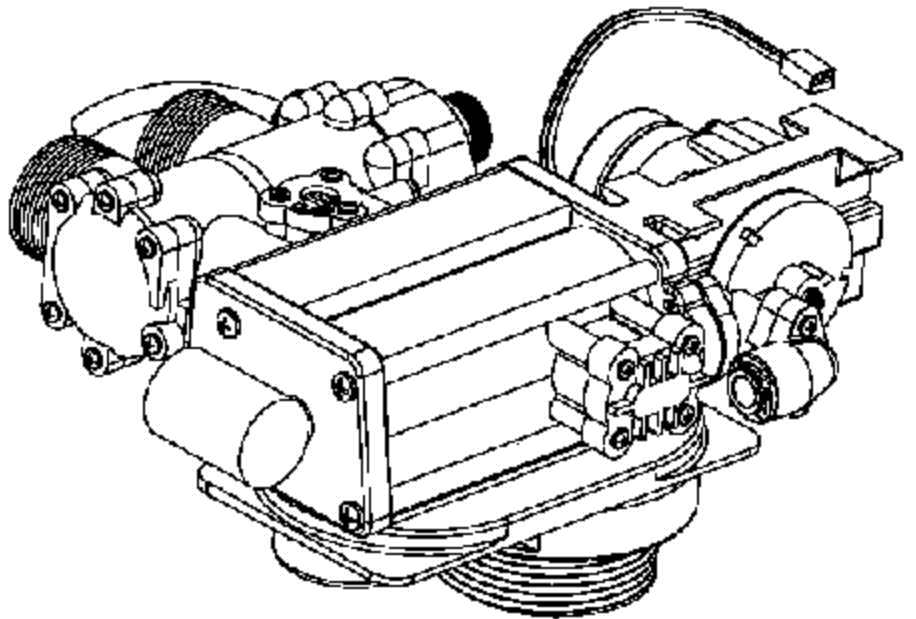

Table of Contents

PREFACE	1
PRE-INSTALLATION	2
INSTALLATION AND START UP	3
EQUIPMENT SPECIFICATIONS	4
SETTING CHARTS	6
CYCLES	8
SETTING THE HYDROCLEAN SYSTEMS CONTROLLERS	10
CARE AND MAINTENANCE	15
PARTS ... VALVE ASSEMBLY	17
PARTS ... HOOK-UP / COVER ASSEMBLY	18
PARTS ... RESIN TANK ASSEMBLY	19
PARTS ... BRINE TANK ASSEMBLY	20
PARTS ... OPTIONAL BRINE TANK ASSEMBLY	21
PARTS ... INJECTOR ASSEMBLY	22
PARTS ... BRINE VALVE HOUSING ASSEMBLY	23
PARTS ... BYPASS ASSEMBLY	24
PARTS ... I/O ADAPTER ASSEMBLY	26
PARTS ... DRIVE END CAP ASSEMBLY	28
PARTS ... DRAIN END CAP ASSEMBLY	30
PARTS ... SAFETY SHUTOFF ASSEMBLY	31
BRINE VALVE ELBOW INSTALLATION INSTRUCTIONS	32
WARRANTY	33

PREFACE

Congratulations on your decision to place your confidence in a superior Hague Hydro-Clean® water treatment appliance.

Recognized nationwide for built-in quality, dependability, and ease of service, these appliances represent state-of-the-art in home water treatment.

While your appliance should be installed and serviced by a professional Hague Hydro-Clean dealer, important

information is contained in this manual which will help you attain the maximum benefit and enjoyment from your particular model.

We urge you to read this information carefully and review it again at any time a malfunction may occur. In most cases, this review will uncover minor problems that you can correct yourself, thereby saving you time and the expense of an unnecessary service call.

HOW TO GET THE MAXIMUM EFFICIENCY FROM YOUR HYDRO-CLEAN APPLIANCE

1. Maintain salt level (for iron filter, see Page 6) at least one-third full; solar salt or pellets and purchase a clean grade of salt. Use one or the other; do not mix pellets and solar salt.
2. Should your electricity be turned off for any reason, more than 16 hours. Reset the time of day according to instructions on page 14.
3. Allow the appliance to regenerate at a time when the water is not being used. If you have more than one appliance, allow two hours between each regeneration.
4. Protect your **Hydro-Clean III** system, including the drain line, from freezing.
5. Should dirt, sand or large particles be present in your water supply, it is important that you consult your Hague dealer to determine the appropriate treatment method that will eliminate this problem.
6. Bypass the appliance if well, plumbing, or pump work is required, and turn on outside tap until water runs clear before putting

the appliance back into service. Your **Hydro-Clean III** appliance may be disinfected with 5.25% sodium hypochlorite, which is the active ingredient in household bleach. To disinfect your appliance, add 4 fluid ounces of hypochlorite solution per cubic foot of resin to the brine well of the brine tank. (the brine tank should have water in it to permit the solution to be carried into the softener). Initiate a manual regeneration.

EXAMPLE:

HCIII 25 = 3.2 oz. Chlorine
HCIII 25CX = 4.0 oz. Chlorine
HCIII 35 = 4.4 oz. Chlorine
HCIII 48 = 6.0 oz. Chlorine
HCIII 64 = 8.0 oz. Chlorine
HCIII 105 = 13.2 oz. Chlorine

OPERATIONAL, MAINTENANCE AND REPLACEMENT REQUIREMENTS ARE ESSENTIAL FOR THE PRODUCT TO PERFORM TO SPECIFICATIONS.

PRE-INSTALLATION CHECK LIST

1. Water Pressure - Not less than 20 PSI constant for models HCIII-(25, 35, 48, 2TN) 30 psi for HCIII-64, 105 and filters.

2. Service Flow Rate - 5 G.P.M. recommended as minimum, 7 GPM for filters.

3. Drain - Drain the appliance to the floor drain or washer drain. To prevent back-siphoning, the installer must provide an adequate air gap or a siphon break.

4. Electricity - Use standard 110 volt A.C. (optional 220 volt available).

5. Water Quality - If water supply contains sulfur, bacteria, iron bacteria, tannins, algae, oil, acid, salt or other unusual substances, special equipment must be installed ahead of the Hydro-Clean III system. See pages 5 and 6.

SOME DO'S

1. Do install after the pressure tank and not between the well pump and pressure tank.

2. Do comply with all local plumbing and electrical codes.

3. Do install pressure reducing valve if inlet pressure exceeds 90 PSI.

4. Do examine the inlet line from the pressure tank to appliance on well water with iron (recommended minimum inlet pipe size 3/4" I.D.). On municipal water, recommended minimum inlet pipe size is 1/2" I.D.

5. Do install gravity drain on salt storage tank.

6. Do secure drain line on appliance and at drain outlet.

7. A minimum of 10 feet of 3/4" pipe from the outlet of the water conditioner to the inlet of the hot water heater is recommended.

8. Do install the drain line so that there is a 2" air gap between the drain line and the drain receptacle.

SOME DON'TS

1. Do not install if previous items are not satisfactory.

2. Do not install if incoming or outlet piping water temperature exceeds 120 °F.

3. Do not allow soldering torch heat to be transferred to valve components or plastic parts.

INSTALLATION and START UP

Place the appliance in the desired location. Turn off the electricity and/or water supply to the water heater. Make sure the inlet, outlet and drain connections meet the applicable local codes. If the appliance has a bypass valve, check the arrows on the bypass valve to be sure the water flows in proper direction. Caution: Do not plumb the appliance in backwards.

The drain hose must be a minimum of 1/2" I.D. tubing and should make the shortest run to a suitable drain.

Connect the salt tank to the valve head with the flexible 3/8" plastic tube included with the system. Be sure to insert the plastic insert in the end of the tube.

Connect the Overflow Line to the brine tank. If the brine tank is filled with too much water, or if there is a malfunction, an overflow line will direct excess water to drain.

The overflow line must end at a drain that is at least 3" lower than the bottom of the overflow fitting. Maintain a minimum of 2" (50 mm) air gap.

Attach the drain line. Route the drain line to a floor drain, laundry tub or other suitable waste receptor. Maintain a minimum of 2" (50 mm) air gap between the drain line and the flood level rim of the waste receptor to prevent back siphoning.

Place the appliance in the bypass position and turn on the main water supply. Open the nearest cold water faucet to flush the plumbing of any excess soldering flux, air, or any other foreign material.

Close the faucet and check for leaks. If leaks are found, turn off the main water supply and open the nearest cold water faucet to depressurize the water line.

Close the faucet to eliminate siphoning action. Repair leaks. Place the bypass in the "service" position. Slowly open the main water supply valve and fill the appliance. Then open the nearest cold water faucet to purge air out of the appliance. Close faucet.

Connect transformer power cord to the back of the controller.

Plug in transformer.

Program the Systems Control as outlined on pages 10 - 16.

Add water to the brine tank. Fill to a minimum of 2" above the grid plate. Make sure that the salt dosage is set as recommended for the application. After the first regeneration, the appliance will automatically refill the correct amount of water into the brine tank.

Put appliance into a manual regeneration and inspect for proper operation. Allow the appliance to draw all the water out of the brine cabinet until the air check sets. Then advance to the brine refill position by using the Immediate Recharge or Change & Select buttons simultaneously (depending on controller). Allow the controller to complete the brine refill sequence of the program and advance to home position. This will replace the necessary volume of water relative to the salt setting.

Fill the brine tank with salt.* Note: Do not mix pellet with solar salt!

* When using potassium chloride as an alternative to sodium chloride, increase the hardness setting by 12%. Note: We do not recommend using potassium chloride when iron is present in the raw water supply.

Open the inlet valve and turn on the electricity to the water heater. To complete the installation, open a cold water tap and allow the appliance to flush for 20 minutes or until approximately 72 gallons have passed through the appliance. Verify flashing light on controller, indicating water flow. Make sure the bypass valve is left in the "service" position.

Replace covers.

PRELIMINARY ENGINEERING SPECIFICATIONS

5-BUTTON DUAL MODE CONTROLLER

	HCI125	HCI125CX	HCI135	HCI145	HCI1B4	HCI1105
Tannin (ppm)	NA	NA	NA	NA	NA	NA
Sulfur (ppm)	NA	NA	NA	NA	NA	NA
Iron in solution (ppm)	2 ²	NA	6 ²	8 ²	10 ²	10 ²
Maximum uncompensated hardness (grains)	60	25	90	110	120	130
Minimum pH	7	7	7	7	7	7
Maximum allowable chlorine (ppm)	1	1	1	1	1	1
Capacity (grains) @ 2.5lbs salt/cu.ft. **	10,700	10,700	14,700	20,100	26,800	44,300
Capacity (grains) @ 3.8lbs salt/cu.ft.	14,700	14,700	20,200	27,500	36,700	60,600
Capacity (grains) @ 5.0 lbs salt/cu.ft.	17,800.	17,800.	24,500.	33,500.	44,800.	73,700.
Capacity (grains) @ 7.0lbs salt/cu.ft.	22,200	22,200	30,500	41,800	55,400	91,500
Capacity (grains) @ 15lbs salt/cu.ft.	25,800	25,800	35,200	48,000	64,000	105,000
Brine line flow control refill (gpm)	.5	.5	.5	.5	.5	.5
Media tank size (Inches) Dia.xHt.	8x44	9x48	9x48	10x54	12x52	14x65
Resin/media amount (cu.ft.)	.8	1.1	1.1	1.5	2.0	3.3
Media type	HCR	HCR/HCM	HCR	HCR	HCR	HCR
Bed depth	30	33	33	36	34	43
Freeboard (Inches)	14	15	15	18	18	22
Water pressure (min.-max. psi)	20-120	20-120	20-120	20-120	30-120	30-120
Water temperature (min.-max. degrees F)	33-120	33-120	33-120	33-120	33-120	33-120
Minimum water volume for backwash	1.5	2.0	2.0	2.4	4.0	5.0
Flow rate gpm @ 15 psi drop	9	10.5	10	12	18	18.5
Pressure drop @ normal flow rate (gpm)	7.8@6	7.2@6	7.6@6	7.3@9	8.5@12	11@14
Pipe size (Inches)	3/4"	3/4"	3/4"	3/4"	1"	1"
Height (Inches)	48	52	52	58	56	69
Floor space (Inches)	18x27	18x28	18x28	18x29	26x36	30x38
Brine or solution tank size (Inches)	18x33	18x33	18x33	18x33	24x50	24x50
Brine or solution tank capacity (lbs.)	375*	375*	375*	385*	640	640
Water volume per regen. (gallons - factory setting)	From 16.5	From 18.5	From 20.6	From 28	From 43.5	From 69
Length of regeneration (minutes)	From 19	From 19	From 23	From 27	From 33	From 46
Shipping weight (approx. lbs.)	100	125	130	160	180	275
Quartz Gravel (lbs)	10	12	12	14	20	30

STANDARD FEATURES:

Metered or timed HCIII valve, Hydro-Clean distributor, high capacity resin and self-leveling thermo media tank.

OPTIONS:

Low profile valve cover, 1" full flow bypass valve.

LEGEND:

2 When iron is present in the raw water supply, regeneration frequency cannot exceed 96 hours. Additionally, a minimum salt setting of 7 lbs. per cubic foot of resin is required and the #1 backwash must be increased to 10 minutes.

N/A: No Application

*325 lbs with grid plate.

** Do not use standard 18" diameter brine tank with salt grid for salt settings less than 3 lbs.

PRELIMINARY ENGINEERING SPECIFICATIONS



Hague Quality Water International, Groveport, OH 43125

5-BUTTON DUAL MODE CONTROLLER - Special Series -

	HCIII2TN	HCIII2IF	HCIII1CF	HCIII1NF	HCIII1MMF
Tannin (ppm)	0-2	NA	NA	NA	NA
Sulfur (ppm)	0	8	0	NA	NA
Iron in solution (ppm)	0	20	0	0 ³	0
Maximum Compensated Hardness (Grains)	10 ⁴	NA	NA	5 ²	NA
Minimum pH	7	7	7	6 ¹	7
Maximum allowable chlorine (ppm)	0	1	2	0	NA
Capacity (grains) @ 2.5 lbs. salt ⁵	(See below)	5,000 ppm*	NA	NA	NA
Capacity (grains) @ 3.0 lbs. salt	NA	NA	NA	NA	NA
Capacity (grains) @ 5.0 lbs. salt	NA	NA	NA	NA	NA
Capacity (grains) @ 7.0 lbs. salt	NA	NA	NA	NA	NA
Capacity (grains) @ 15.0 lbs. salt ⁵	NA	NA	NA	NA	NA
Brine line flow control valve (cm)	.5	.5	NA	NA	NA
Media tank size (Inches) Dia. x Ht.	8x44	10x47	10x47	10x47	10x47
Resin/media volume (cu.ft.)	.7	1.0	1.33	1.26	1.5
Media Type	Anion Resin	GreenSand	HydraChar	DeltaCarbons	Multi-Grade
Bed depth (Inches)	28	28.5	33.75	32	33
Freeboard (Inches)	16	19.5	12.25	14	13
Water pressure (min.-max. psi)	20-120	30-120	30-120	35-120	30-120
Water temperature (min.-max. degrees F)	35-120	35-80	35-120	35-120	33-120
Minimum water volume for backwash	1.2	6.0	5.0	5.0	7.0
Flow rate gpm @ 15 psi drop	4	8	8	8	8.5
Pipe size (Inches)	3/4"	3/4"	3/4"	3/4"	3/4"
Height (Inches)	48	51	51	51	51
Floor space (Inches)	11x27	11x27	11x11	11x11	11x11
Brine or solution tank size (Inches)	11x33	11x21	NA	NA	NA
Brine or solution tank capacity (lbs.)	325	564.8404	NA	NA	NA
Water volume per regen. (gallons - factory setting)	20.5	57.5	35	35	49
Length of regeneration (minutes)	37	55	7	7	7
Shipping weight (approx. lbs.)	90	175	100	175	175

*Uses 4 oz. Potassium Permanganate (KmNO₄.) See HCIII- 2IF below

SPECIAL SERIES

Standard: HCIII valve, self leveling thermo media tank, 3/4" inlet/outlet adaptor, 1" high flow distributor. Option: Built-in bypass with test port, tank jacket, salt shelf.

Streamline brine tank - 11" X 11" X 34" (not available for 2TN, 2IF, 64 or 105.)

HCIII1CF: Removes tastes, odors and will reduce most man-made pollutants. Backwashes as needed.

HCIII1NF: Designed to raise the pH of most low pH water. The mineral media must be replenished periodically. Backwashes every 2 days.

HCIII2TN: Designed to remove tannin from iron and sulfur free water. Regenerates every 4th day with 6 lbs. of salt. Add 4-oz. of 5¼% chlorine every 6 weeks.

HCIII2IF: Removes iron and iron algae. Also removes up to 5 ppm H₂S with the presence of 2ppm iron. Regenerates every 6 days for iron; as needed for sulfur.

HCIII1MMF: Designed to remove heavy sediment and suspended solids. It is capable of filtering down to 10 microns in size. Backwashed as needed.

LEGEND:

1 CAUTION: The HCIII1NF will raise the pH of most, but not all low pH water. Some water requires the addition of caustic soda with a chemical feed pump.

2 When iron is present in the raw water supply, regeneration frequency cannot exceed 96 hours. Additionally, a minimum salt setting of 7 lbs. per cubic foot of resin is required and the #1 backwash must be increased to 10 minutes.

3 Not available with 3-button controller.

4 Water containing 10 grains of hardness or more should be softened prior to the tannin removal unit. To prevent organic fouling, do not exceed 4 days between regenerations.

N/A: No Application

HCIII SPECIAL SERIES SETTING CHART



	HCIII21F	HCIII1CF	HCIII1MMF	HCIII INF	HCIII2TN
Capacity (ppm)	8,000	N/A	N/A	N/A	2 Tannin
Sulphur H ₂ S (ppm)	5	N/A	N/A	N/A	0
Iron (ppm)	20	N/A	N/A	N/A	0
Minimum pH	7	N/A	N/A	5	7
Media Type	Manganese Greensand	Activated Carbon	Multi-Grade	Calcite/Corosex	Anion Resin
Media Amount (cu. ft.)	1.0	1.33	1.5	1.25	.7
Quartz Gravel (lbs)	14	14	16*	14	10
Media Tank Size (in.)	10 X 47	10 X 47	10 X 47	10 X 47	8 X 44
Backwash Rate (gpm)	5.0	5.0	7.0	5.0	1.2
Brine Line Flow Control (gpm)	.5	N/A	N/A	N/A	.5
Water Pressure	30 - 120	30 - 120	30 - 120	30 - 120	20 - 120
Mode Setting	1	1	1	1	1
Backwash #1 (min)	5	7	7	7	5
Brine/Rinse (min)	45	0	0	0	30
Backwash #2 (min)	2	0	0	0	2
Salt (lbs) or Salt Substitute	3	0	0	0	7
Regenerant Used	4 oz. KMnO ₄ Potassium Permanganate	N/A	N/A	N/A	Salt
	This unit removes H ₂ S with the presence of at least 2 ppm iron.	Backwash only unit. Must not be backwashed for 24 hours after installation.	Backwash only unit. Backwashes every 3 days or as needed.	Backwash only unit. Must backwash at least every two days or media may solidify. Will add some hardness to water.	Regenerates every 4 days.

*The HCIII1MMF uses garnet for an under bed instead of quartz gravel.

HCIII SETTING CHART



MODE 1 & 2 SETTINGS

Dual mode five button controller

		*HCIII25†	††HCIII25GX	*HCIII35†	*HCIII45†	*HCIII54†	*HCIII105†
#1 S A L T	Backwash 1 (minutes)	6	6	6	6	6	6
	Brine and slow rinse	9	8	13	18	12	15
	Backwash 2 (minutes)	2	2	2	2	2	2
	Salt (lbs) / Capacity **	2.0/10,700	2.0/10,700	2.8/14,700	3.8/20,100	5.0/26,800	8.3/44,300
#2 S A L T	Backwash 1 (minutes)	6	6	6	6	6	6
	Brine and slow rinse	14	14	19	26	18	23
	Backwash 2 (minutes)	2	2	2	2	2	2
	Salt (lbs) / Capacity	3.0/14,700	3.0/14,700	4.2/20,200	6.7/27,500	7.8/38,700	12.5/60,600
#3 S A L T	Backwash 1 (minutes)	6	6	6	6	6	6
	Brine rinse (minutes)	18	18	25	35	24	30
	Backwash 2 (minutes)	2	2	2	2	2	2
	Salt (lbs) / Capacity	4/17,800	4/17,800	5.5/24,500	7.5/33,800	10/44,600	16.5/73,700
#4 S A L T	Backwash 1 (minutes)	6	6	6	6	6	6
	Brine rinse (minutes)	26	26	36	48	34	42
	Backwash 2 (minutes)	2	2	2	2	2	2
	Salt (lbs) / Capacity	5.6/22,200	5.6/22,200	7.7/30,500	10.5/41,800	14/55,400	23.1/91,500
#5 S A L T	Backwash 1 (minutes)	6	6	6	6	6	6
	Brine rinse (minutes)	55	55	75	99	72	91
	Backwash 2 (minutes)	4	4	4	4	4	4
	Salt (lbs) / Capacity	12/25,600	12/25,600	16.5/35,200	22.5/48,000	30/64,000	49.5/105,000

* If iron is present in the water supply, set #1 backwash to 10 minutes.

† When iron is present in the water supply, regeneration frequency cannot exceed 96 hours. Additionally, a minimum salt setting of 7 lbs. per cubic foot of resin is required (#4 salt setting.)

†† This unit is designed for use on chlorinated, municipal water supplies only. Reduces tastes, odors, chlorine and most man-made pollutants.

** Do not use standard 18" diameter brine tank with salt grid for salt settings less than 3 lbs.

CYCLES

CYCLE 1

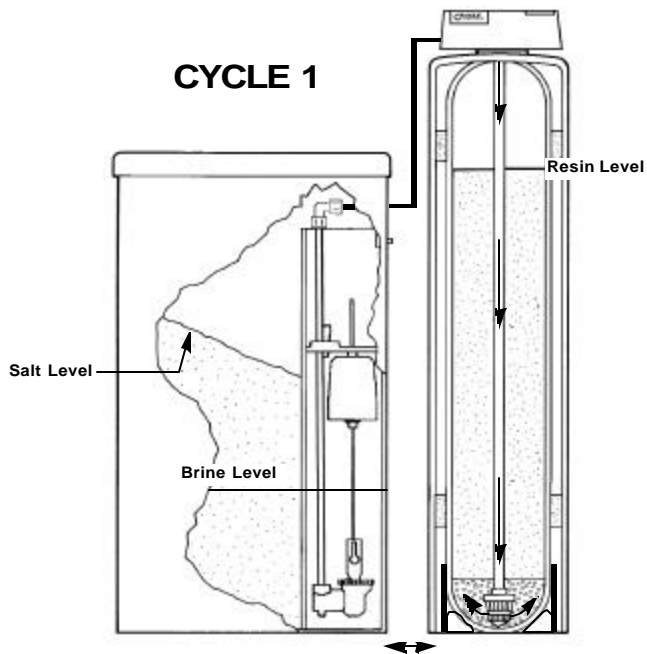

1. First up-flow backwash. A rapid up-flow of water flushes out the resin bed and cleans the sediment filter.

2. Brine. Brine is drawn out of the brine cabinet and up through the media tank, cleaning the resin bed and releasing accumulated hardness and iron.

CYCLE 2

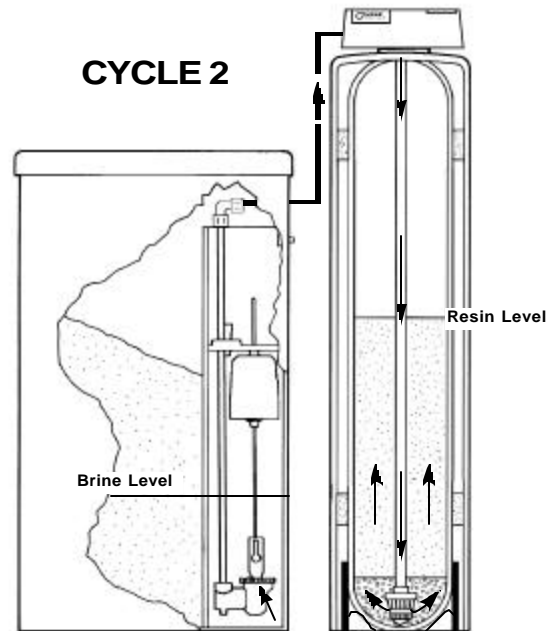

CYCLE 3

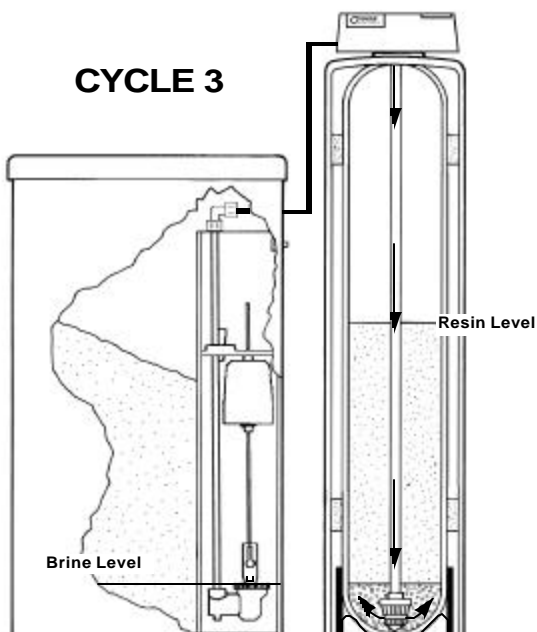

3. Slow rinse. A slow up-flow rinse process then flushes out the brine, hardness and iron.

CYCLES

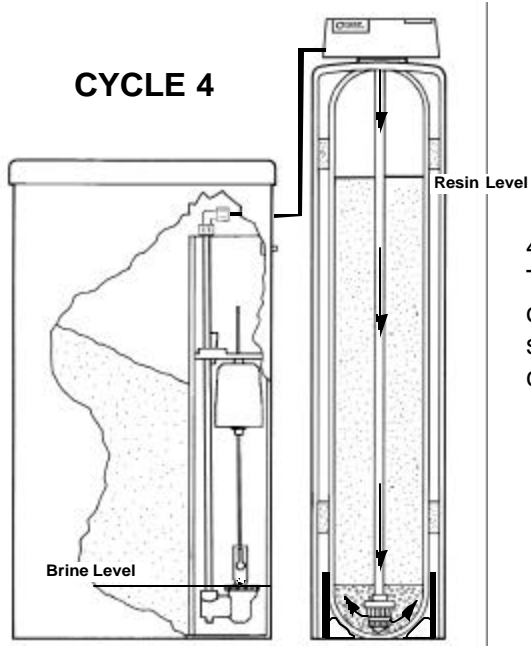

4. Second up-flow backwash. This up-flow backwash flushes out any remaining brine solution and sediment from cycle 2.

5. Downflow soft water brine refill. Soft water is directed to the brine cabinet to prepare the brine for the next regeneration sequence.

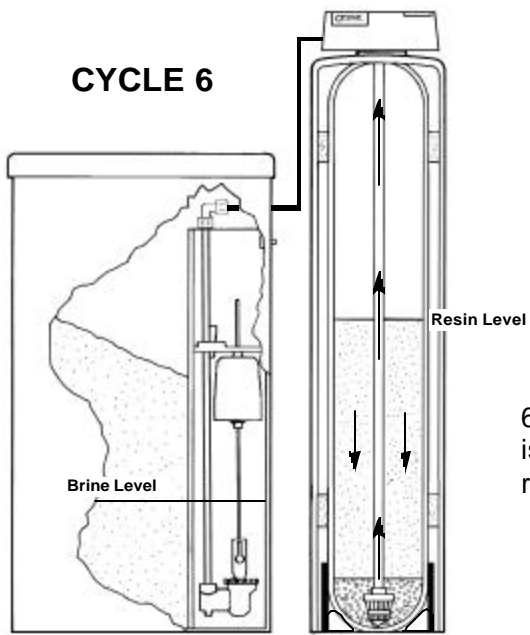
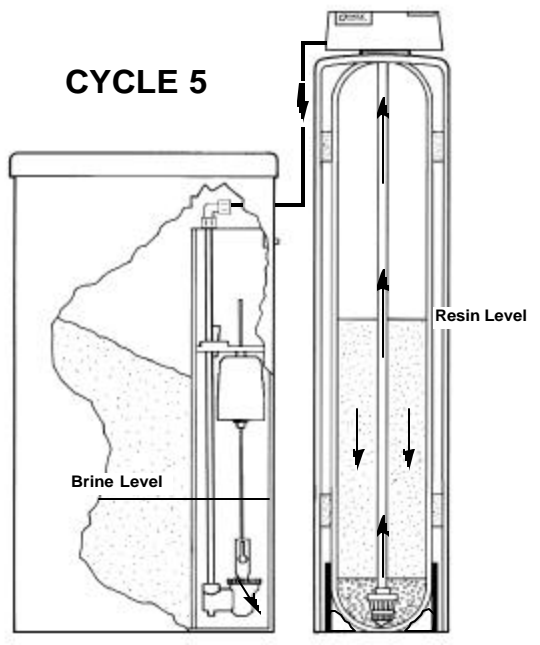

6. Return to service. Regeneration is complete and the appliance is returned to normal operation.

SETTING & USING THE APPLIANCE CONTROL

SERVICE SETTINGS

This section is recommended for qualified service personnel only. The appliance control must be set correctly for proper performance.

REGENERATE

FUNCTION: Multi-purpose. 1.) Used to put the appliance into an immediate regeneration. Press and hold (approximately 5 seconds) until display changes to "Going to 1". The appliance is now in regeneration and will return to "Gal. Remain" after completion of all cycles. 2.) Used to "speed up" or toggle through all the regeneration cycles.

CUSTOMER SETTINGS

This section is recommended for qualified service personnel only. Must be set correctly for proper performance.

CHANGE

FUNCTION: Used to change values of parameters that can be set. Used in conjunction with SELECT button. Press and release the Select Digit button to move cursor one digit to the right of parameter that can be set. When cursor is at extreme right position, press again to reset cursor to extreme left position.

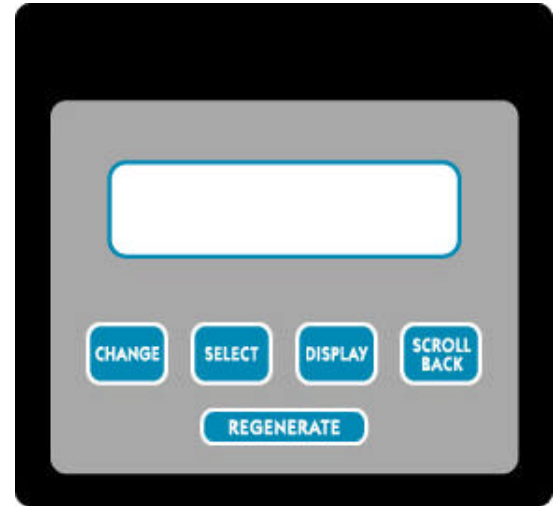

figure 2

SELECT

FUNCTION: Used to control cursor movement when in CUSTOMER & SERVICE SETTINGS modes. Used in conjunction with CHANGE button. Press and release the Select Digit button to move cursor one digit to the right of parameter that can be set. When cursor is at extreme right position, press again to reset cursor to extreme left position.

DISPLAY

FUNCTION: When pressed and held, "CUSTOMER SETTINGS" is displayed. Hold for 5 seconds and the customer programming mode is entered. Used simultaneously with the SELECT button to enter service settings program mode, press and hold both buttons for 5 seconds while holding "SERVICE SETTINGS" is displayed. (Note: both buttons must be pressed.)

SCROLL BACK

FUNCTION: Used to toggle back to the previous parameter setting in the event of a mistake in programming. This feature eliminates the need to toggle through the entire program to correct an input error.

CONTROL PANEL DISPLAY:

LCD DISPLAY

FUNCTION: Shows status of control; NORMAL OPERATING mode, SERVICE SETTINGS mode or CUSTOMER SETTING mode. It is very important to know which mode the control is in for proper operation.

WATER FLOWING INDICATOR

FUNCTION: Shown in the LCD display, it indicates that water is flowing through the HCIII. Flow rate is displayed in gallons per minute. This is useful for checking for proper plumbing and leaks.

SETTING & USING THE APPLIANCE CONTROL

Description Of The Two HCIII Operating Modes

CAUTION: Be sure the controller is firmly "locked" onto the drive end cap assembly." The four tabs on top of the drive end cap will allow the clips on the bottom of the controller case to lock onto the end cap tabs. (See detail diagram on page 19; fig. 3.)

MODE 1

TIMER MODE: Will regenerate based on frequency. Example: every 2 days or as specified up to 12 days. Time of regeneration can be set.

MODE 2

PATENTED SAVEMATIC - DEMAND DELAYED: Is based on actual water usage and total capacity of the appliance. Time of regeneration can be set. If total capacity is depleted before set regeneration time, a forced regeneration will occur.

Note: Mode 1 and 2 are equipped with capacity Gard. This ensures that you do not run out of conditioned water due to excess water usage.

THE FOLLOWING EXAMPLE takes you through the steps involved for setting the HCIII SYSTEM CONTROL. If you follow these steps, you will set HCIII 35 for OPERATING MODE 2, DEMAND DELAYED operation. Mode 1 uses a similar procedure. It is necessary to enter the "SERVICE SETTINGS" first, followed by the "CUSTOMER SETTINGS". Press and hold the SELECT and DISPLAY buttons simultaneously for 5 seconds. The display will show, "Soft Vers. 01.0". Release both buttons.

- 1.00 Push the CHANGE DIGIT button until the correct language is displayed. In this example, set to: Set Language ENG.
- 2.00 Push the DISPLAY button to step to the next parameter. The display will show: **Units ENG**
- 2.00a Push the CHANGE button to toggle English/metric units of measure. For this example, set to: Units ENG.
- 3.00 Push the DISPLAY button to step to the next parameter. The display will show: **Mode 2** The "Mode #" is the number of the OPERATING MODE for which the systems control is set. For this example, leave at: Mode 2.
- 4.00 Push the DISPLAY button to step to the next parameter. The display will show: **Hard. Gr. 040** The 040 is the hardness number of the water tested. This number is to be the actual hardness reading and is not compensated for iron.
- 4.00a Push and release the SELECT button until the cursor (_) is positioned in the display as follows: **Hard. Gr. 040**. The cursor is now under the "ten" position.
- 4.00b Continue pushing the SELECT and CHANGE buttons until the desired hardness number is displayed. Example: **Hard. Gr. 025**
- 5.00 Push the DISPLAY button to step to the next parameter. The display will show: **Iron ppm 00**
This parameter is used to calculate a compensated hardness automatically.
- 5.00a Push the SELECT and CHANGE buttons until the desired iron number is displayed. Example: **Iron ppm 00**
- 6.00 Push the DISPLAY button to step to the next parameter. The display will show: **Mang. ppm 00**
- 6.00a Push the SELECT and CHANGE buttons until the desired manganese number is displayed. Example: **Mang. ppm 00**
- 6.00b Push the DISPLAY button to step to the next parameter. The display will show: **SALT = Sodium.**
WARNING! When iron and/or manganese is present in the water supply, do not use potassium chloride as a regenerant. Iron and/or manganese bacteria may develop and foul the conditioning media and may void the warranty.
- 6.00c Push the SELECT and CHANGE buttons until the desired regenerant is selected. EXAMPLE: Salt = Sodium.

SETTING & USING THE APPLIANCE CONTROL

- 7.00 Push the DISPLAY button to step to the next parameter. The display will show: **Comp. Hard. 00025**
This parameter is the calculated compensated hardness using the hardness, iron and manganese settings. The formula is (4 x each ppm iron) + (4 x each ppm manganese) + hardness = compensated hardness. This is not a parameter that can be set. The display should now read: **Comp. Hard. 00025**
- 8.00 Push the DISPLAY button to step to the next parameter. The display will show: **Capty. Gr. 28730**
This parameter is used to set the softening capacity of the appliance. (See WaterMax engineering specifications or setting charts for capacities based on salt usage.)
- 8.00a Push the SELECT and CHANGE buttons until the desired capacity number is displayed.
In this example, set to: **Capac. Gr. 24500**
- 9.00 Push the DISPLAY button to step to the next parameter. The display will show: **72-96hr Regen Yes**
This parameter, if set to "Yes", is used to force the appliance to regenerate every 96 hours if regularly scheduled regenerations based on water usage do not occur in 96 hours or less intervals. This should always be "yes" if iron is present in the water.
- 9.00a Push CHANGE button to toggle parameter value from "No" to "Yes". In this example, set to: **96hr Regen No**
- 10.00 Push the DISPLAY button to step to the next parameter. The display will show: **Backwash 1 01.0**
(See Mode 1 & 2 setting chart.) The "01.0" is the time, in minutes to the nearest tenth, for which the first backwash cycle can be set.
- 10.00a Push the SELECT and CHANGE buttons until the desired backwash time is displayed.
In this example, set to: **Backwash 1 06.0**
- 11.00 Push the DISPLAY button to step to the next parameter. The display will show: **Brine/Rinse 30.0**
The "30.0" is the time, in minutes to the nearest tenth, for which the first brine and slow rinse cycles can be set.
- 11.00a Push the SELECT and CHANGE buttons until the desired combined brine and slow rinse cycle time is displayed. In this example, set to: **Brine/Rinse 25.0**
- 12.00 Push the DISPLAY button to step to the next parameter. The display will show: **Backwash 2 05.0**
The "05.0" is the time, in minutes to the nearest tenth, for which the second backwash can be set.
- 12.00a Push the SELECT and CHANGE buttons until the desired backwash time is displayed.
In this example, set to: **Backwash 2 02.0**

SETTING & USING THE APPLIANCE CONTROL

- 13.00 Push the DISPLAY button to step to the next parameter. The display will show: **Salt lbs. 06.2**
This parameter sets the amount of salt to be used to achieve the capacity setting.
- 13.00a Push the SELECT and CHANGE buttons until the desired salt setting is displayed.
In this example, set to: **Salt lbs 05.5**
- 14.00 Push the DISPLAY button to step to the next parameter. The display will show: **Turbine Test NO**
This feature should only be used by qualified service personnel. It is intended to be used for diagnostic purposes only. **WARNING! Do not engage this feature.**
- 14.00a Push the SELECT and CHANGE buttons until the correct value is displayed.
In this example, set to: **Turbine Test NO**
- 15.00 Push the DISPLAY button to step to the next parameter. The display will show: **Reg. Tonight NO**
This parameter, if set to YES, will force a regeneration at the next set regeneration time (i.e. 02.00.) After the regeneration, the parameter will automatically reset to "No."
- 15.00a Push the CHANGE button to toggle between Yes or No. In this example, set to: **Reg. Tonight YES**
- 16.00 Push the DISPLAY button to step to the next parameter. The display will show: **Filter? No.**
This parameter, if set to YES, is for model selection only and has no effect on the function of the appliance. In this example, set to: **Filter, NO.**
- 17.00 Push the DISPLAY button to step to the next parameter. The display will show:
Gal. Remain 00980

SETTING & USING THE APPLIANCE CONTROL

This is the normal operation display for OPERATING MODE 2. The 00980 represents the number of gallons of softening capacity between regenerations. This completes the SERVICE SETTINGS mode. Even though the SERVICE SETTING mode has been completed, the HCIII 35 is not ready for service until the CUSTOMER SETTINGS mode is completed. The following example takes you through the steps required for setting the parameters of the CUSTOMER SETTINGS mode for OPERATING MODE 2.

- 1.00 Push and hold the DISPLAY to enter CUSTOMER SETTINGS mode. The display will show: **Set Time 00:00 AM** This parameter is to be set to the current time of day.
- 1.00a Push the SELECT and CHANGE buttons until the desired time is displayed. In this example, set time to: Example: 11:00 AM or 05:00 PM.
- 2.00 Push the DISPLAY button to step to the next parameter. The display will show: **Reg Time 02:00 AM** This parameter is to be set for the desired time a normally scheduled regeneration is to occur.
- 2.00a Push the SELECT and CHANGE buttons until the desired time is displayed. In this example, set to: Reg. Time 02:00. (02:00 is 2:00am)
- 3.00 Push the DISPLAY button to step to the next parameter. The display will show: **# People 04**
- 3.00a Push the CHANGE button until the correct number of people in the household is displayed. In this example, set to: **# People 05**
- 5.00 Push the DISPLAY button to save the parameter settings and exit the CUSTOMER SETTINGS mode. The display will show: **Gal Remain 00980**

If you followed the above directions correctly, your HCIII Systems Control is ready for OPERATING MODE 2 service.

CARE AND MAINTENANCE

PROBLEM	CAUSE	ACTION
No soft water after regeneration.	No salt in brine tank.	Add salt.
	Sediment in brine tank has plugged the brine line and/or air check.	Remove the brine line and flush clean. Clean air check. Clean brine tank.
	Refill flow control is plugged.	Remove brine piston housing and clear debris from the flow control.
	Drain line is pinched, frozen or restricted.	Straighten, thaw or unclog the drain line.
	Clogged injector assembly.	Remove injector cap and clean nozzle and throat with a wooden toothpick. Replace throat if removed.
	Salt bridge has formed.	High humidity or the wrong kind of salt can create a salt bridge. This is a crust that forms an empty space between the water and salt. To test, use a blunt object like a broom handle. Push the handle into the salt to dislodge the salt bridge.
No soft water	The plumbing bypass valve is in the bypass position.	Place bypass valve in the service position.
	Appliance is plumbed in backwards.	Check that appliance is plumbed correctly.
	Extended power outage.	Reset hardness.
	Water hardness has increased.	Retest water and reset hardness.
	Not metering water.	Flow should be indicated with water usage. If no flow, see below.
	Blending dial open.	Make sure blending dial is closed.
No flow is indicated when water is flowing.	The bypass valve is in the bypass position.	Place bypass in the service position.
	Appliance plumbed in backwards.	Check that appliance is plumbed properly.
	Sensor not receiving signal from magnet.	Remove sensor from I/O housing. Test with magnet on each flat side of sensor. One side should indicate flow, the other will not. If flow is indicated, check turbine. If no flow, replace sensor.
	Turbine is jammed.	Remove bypass valve and clear debris from turbine.
Flow is indicated when water is not being used.	There is a leak in your household plumbing system.	Repair the leak.
No read-out in display.	Electric cord is unplugged.	Plug in transformer.

CARE AND MAINTENANCE

PROBLEM	CAUSE	ACTION
No read-out in display.	No electric power at outlet.	Check power source. Make sure outlet is not controlled by a switch.
	Defective transformer.	Test with volt meter for 12VAC at controller. If less than 10VAC or greater than 14VAC, replace transformer.
	Defective circuit board.	With 12VAC present at controller, replace computer controller.
	High ambient temperature. If temperature exceeds 120° F, display will blank out. This does not affect the operation of the controller.	
Appliance stays in regeneration. Cycle display remains "going to _?_".	Controller not snapped into place.	Snap controller into place. See pg. 18
	Defective magnet disc.	Replace magnet disc.
	Foreign object in valve body.	Remove foreign objects from valve body.
	Broken valve assembly. Motor running. Magnet disc not turning.	Repair drive end cap.
Excess water in brine tank.	Restricted, frozen or pinched drain line.	Remove restriction, thaw or straighten drain line.
	Plugged brine line, brine line flow control or air check.	Clean flow control, air check and brine line.
	Plugged injector assembly.	Clean or replace injector. Replace throat if removed.
	Sticking brine refill valve.	Remove valve. Lubricate piston with silicone grease and reassemble.
Not regenerating in proper sequence.	Defective magnet disc.	Replace magnet disc.
	Defective controller.	Replace controller.
Salty water.	Plugged Injector.	Clean injector screen, nozzle and throat See page 22.
	Low water pressure.	Maintain min. pressure of 30 psi.
	Brine line restricted or crimped.	Remove restrictions, replace if crimped.
	Excessive amount of water in brine cabinet.	Verify correct water level relative to salt setting. Check lines for loose connections.
	Insufficient rinse time.	See mode settings (page 7). Adjust time if necessary.

PARTS ... VALVE ASSEMBLY

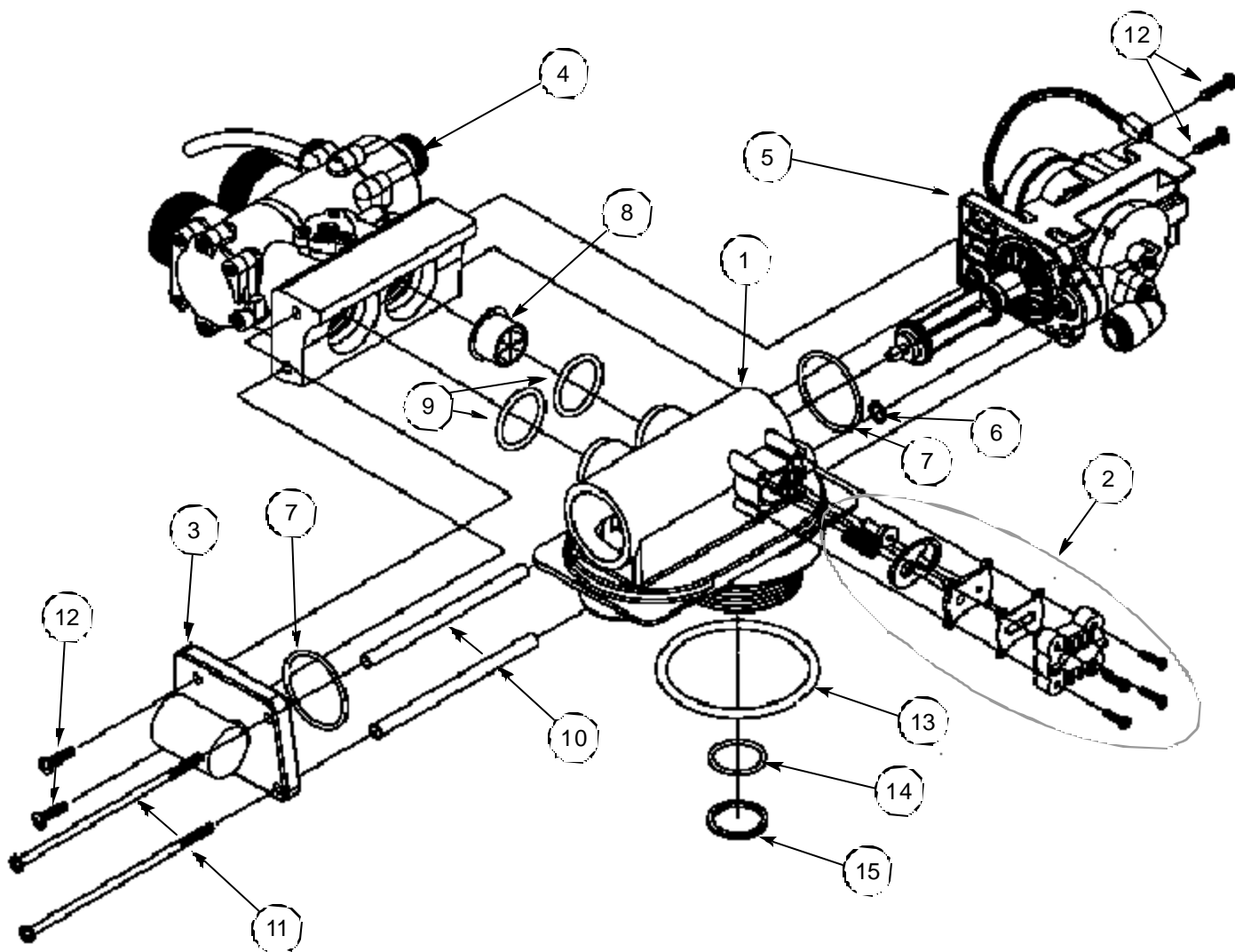

PART#	DESCRIPTION	QUANTITY	PART#	DESCRIPTION	QUANTITY
1	53000 Valve Housing	1	10	93835 Spacer Tube	2
2	93501 Injector Assembly	1	11	93809 End Cap Screw	2
3	90614 Drain Endcap Assembly	1	12	93870 End Cap Screw	4
4	90615-94 Bypass Assembly	1	13	H2281 Tank O-ring	1
5	95301T-JG Drive Endcap Assembly *	1	14	H3304 Pilot O-ring	1
6	90828 Small End Cap O-ring	1	15	53004 Pilot O-ring Retainer	1
7	93808 End Cap O-ring	2			
8	93229 Flow Director	1			
9	93838 I/O Adapter O-ring	2			

* This assembly does not include a magnet disc or drive motor, and must be ordered seperately.

PARTS ... HOOK-UP / COVER ASSEMBLY

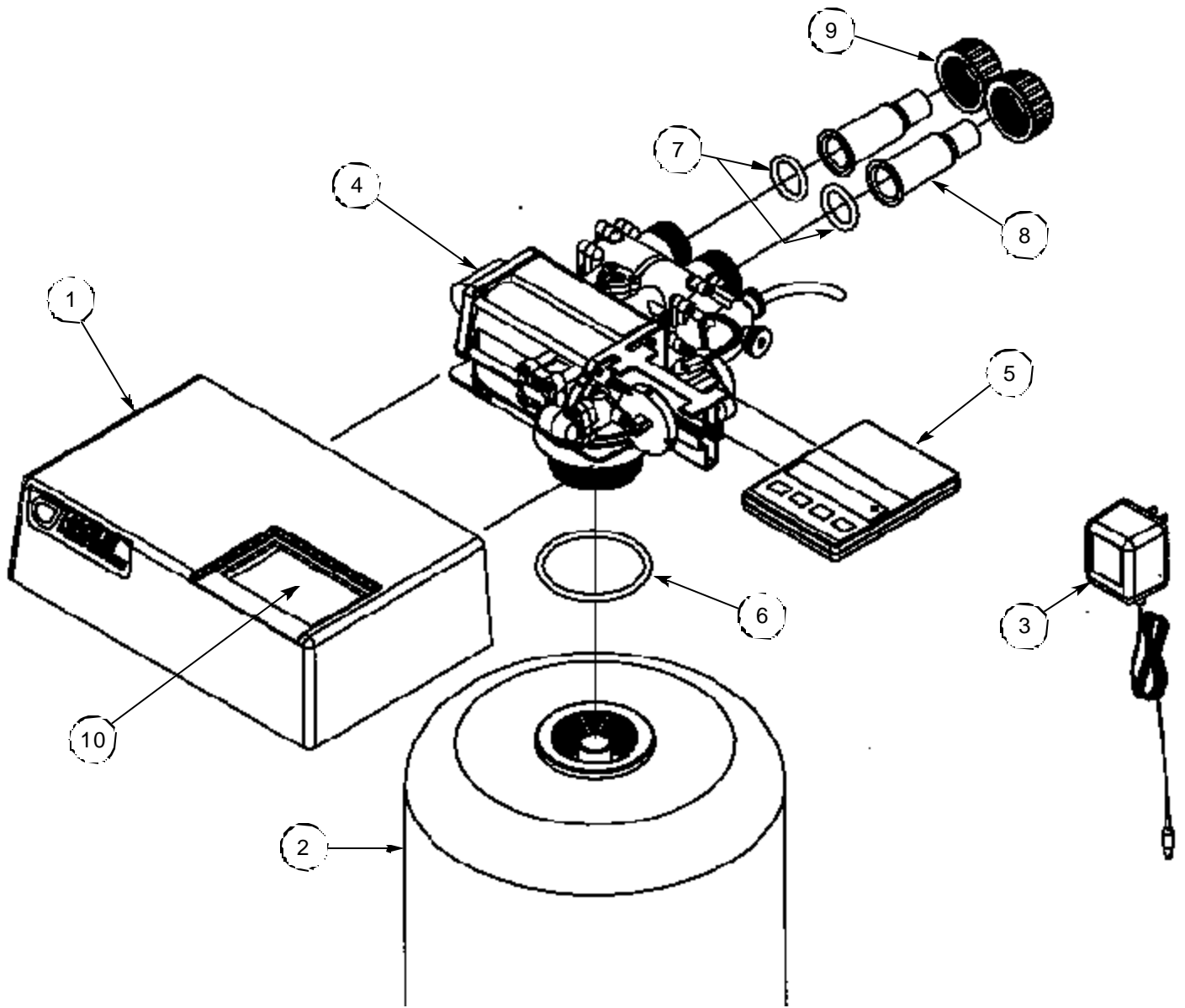

Controller Tab Lock Detail

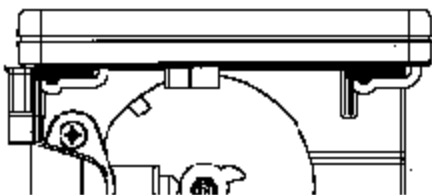

Correct

Incorrect

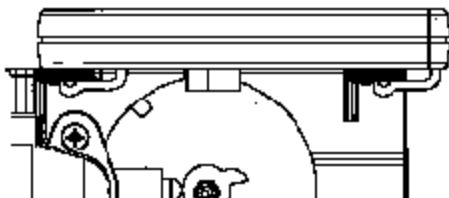

PART#	DESCRIPTION	QUANTITY
1	53500 Valve Cover W/Label	1
2	BT844 Resin Tank Jacket	1
	BT948 Resin Tank Jacket	
	BT1047 Resin Tank Jacket	
	BT1054 Resin Tank Jacket	
3	93245 Transformer	1
4	53501 Valve Assembly w/O-ring	1
5	54550 5 Button Controller	1
6	H2281 Tank O-ring	1
7	90837 Hook Up O-ring	2
8	90254 Copper Adapter	2
9	90251 Bypass Nut	2
	90256 PVC Adapter (optional)	2
10	95209 Clear Viewing Panel	1

PARTS ... RESIN TANK ASSEMBLY

PART#	DESCRIPTION
1	BT 844 Thermo Jacket - 44
	BT 1047 Thermo Jacket - 47
	BT 948 Thermo Jacket - 48
	BT 1054 Thermo Jacket - 54
2	C1400 Thermo Foam - 8"
	C1430 Thermo Foam - 9"
	C1480 Thermo Foam - 10"
3	MT844 Thermo Tank - 8"X44"
	MT948 Thermo Tank - 9"X48"
	MT1047 Thermo Tank - 10"X47"
	MT1054 Thermo Tank - 10"X54"
	MT1252 Thermo Tank - 12"X52"
	MT1465 Thermo Tank - 14"X65"
4	CAS-820 1" Riser HCIII Special Series
	CAS-822 1" Riser HCIII 2TN, 25
	CAS-823 1" Riser HCIII 25CX, 35
	CAS-824 1" Riser HCIII 48
	CAS-827 1" Riser HCIII 64
	CAS-828 1" Riser HCIII 105
5	M010 Resin - C249
	M030 Manganese Greensand
	M048 Activated Carbon
	M050 Calcite
	M060 Corosex
	M090 Calcite / Corosex Mix
6	M035 Quartz Gravel
7	MT181 Adjustable Base - 8"
	MT182 Adjustable Base - 9"
	MT183 Adjustable Base - 10"

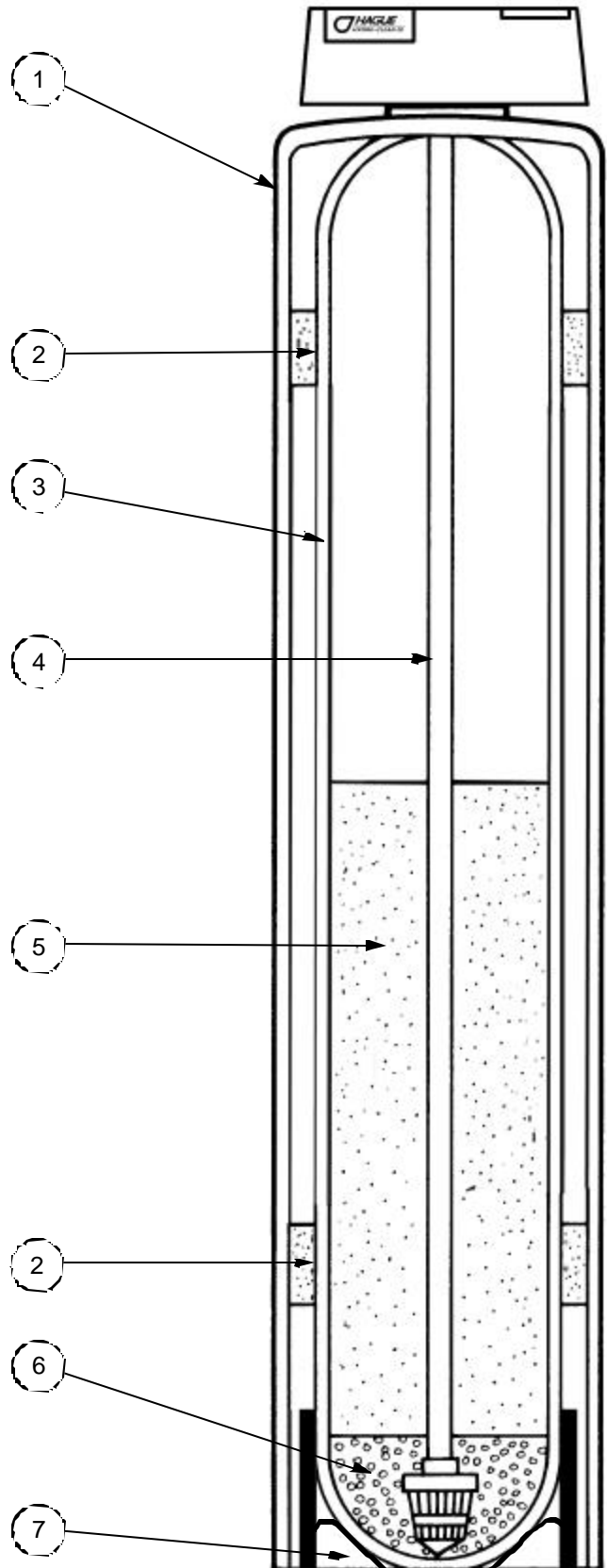

PARTS ... STANDARD BRINE TANK ASSEMBLY

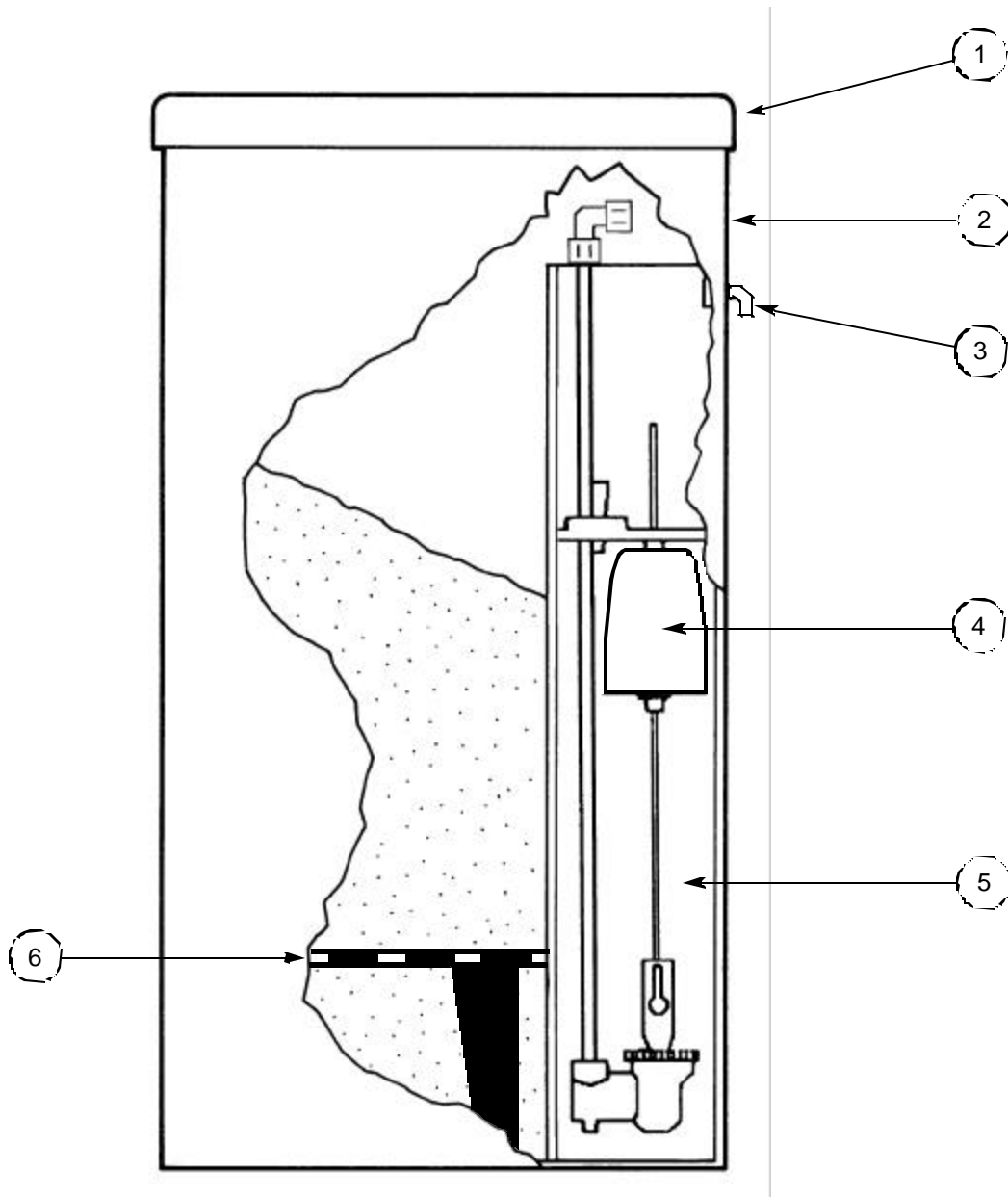

PART#	DESCRIPTION	QUANTITY
1 BT055	Brine Tank Cover	1
2 BT1833-HWC	Brine Tank	1
3 C0700	Overflow Fitting	1
4 93811-26.5	Air Check Assembly	1
5 C0800	Brine Well	1
6 C0650	Grid Plate	1
7 93848	3/8" X 5' Brineline (not shown)	
53560	Brine Tank Assembly (contains items 1-7)	

PARTS ... OPTIONAL BRINE TANK ASSEMBLY

**HCIII Square Brine Tank
15" X 15"**

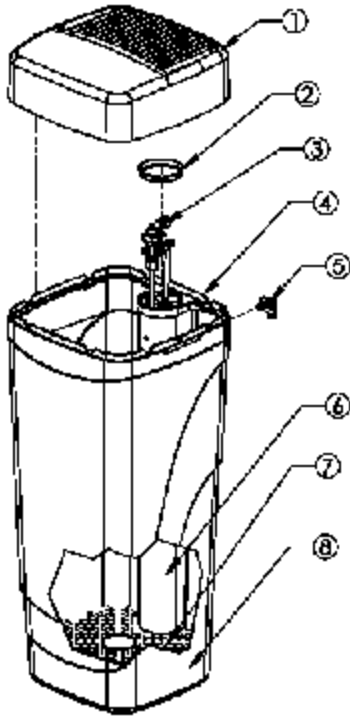

**Compact Brine Tank
11" X 11"**

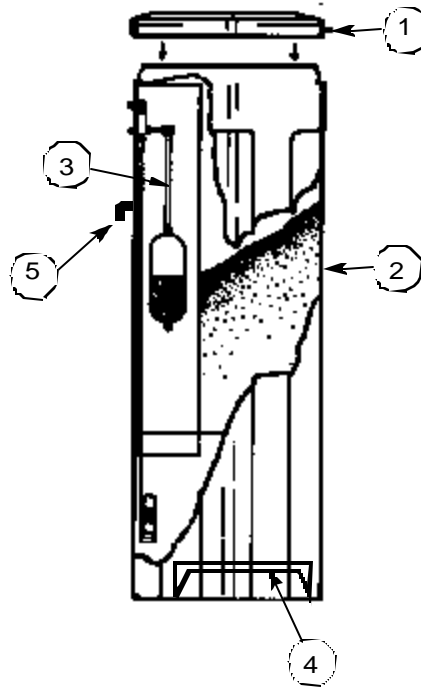

Potassium Tank

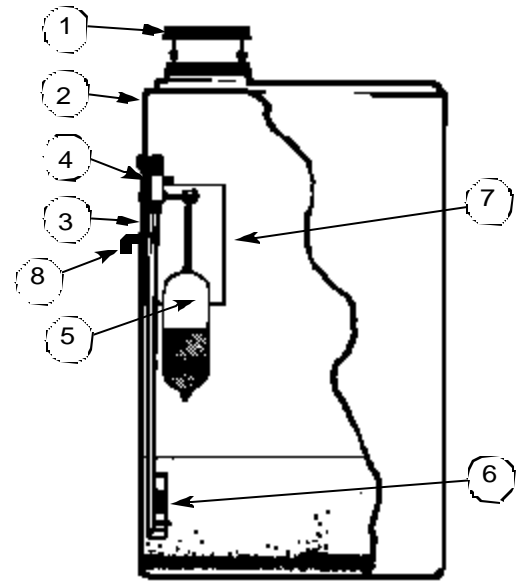

PART#	DESCRIPTION	QUANTITY
1	54006 Brine Tank Cover	1
2	90103 Brine Well Cap	1
3	54525 Safety Shutoff Assembly	1
4	54007 Support Panel (BT)	1
5	CO700A Cabinet Overflow	1
6	54008 Brine Well	1
7	54009 Grid Plate	1
8	54003 Cabinet	1

PART#	DESCRIPTION	QUANTITY
1	BT092 Compact Brine Tank Lid	1
2	BT1134 Compact Brine Tank	1
3	93811-26.5 Air Check Assembly	1
4	C0675-3.5 Compact Grid Plate	1
5	CO700 2 Piece Overflow	1
6	93848 3/8" Brine Line (not shown)	
	53570 Compact Brine Tank Assembly (contains items 1-6)	

PART#	DESCRIPTION	QUANTITY
1	BT1425 Pot. Tank Cover	1
2	BT1424 Solution Tank	1
3	H5300-IF Air Check Assy., Iron Filter	1
4	H5228 Safety Brine Valve	1
5	10700-IF Float Assy., Iron Filter	1
6	H5785-IF Air Check, Iron Filter	1
7	C0830 3' X 6" Brine Well	1
8	CO700 2 Piece Overflow	1
9	93848 3/8" Brine Line (not shown)	
	UAS-120 Potassium Tank Assembly (contains items 1-9)	

PARTS ... INJECTOR ASSEMBLY

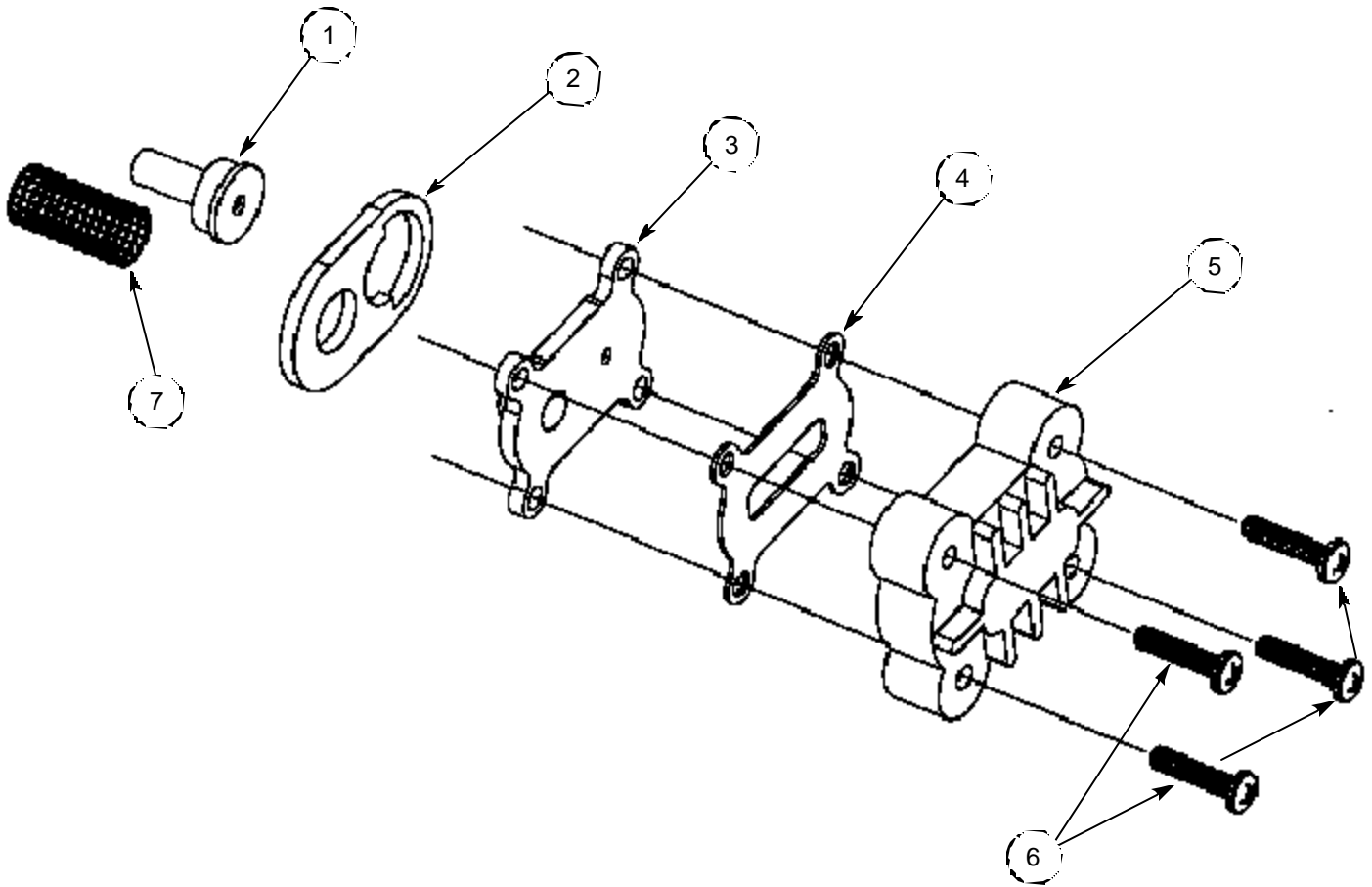

	PART#	DESCRIPTION	QUANTITY
1	93223	Injector Throat	1
	93223-64*	Injector Throat	
	93223-105**	Injector Throat	
2	93220	Bottom Injector Seal -thick	1
3	93221	Injector Nozzle	1
	93221-64*	Injector Nozzle	
	93221-105**	Injector Nozzle	
4	93232	Top Injector Seal - thin	1
5	93222	Injector Cap	1
6	90807	Injector Screw	4
7	93810	Injector Screen	1
	93501	Injector Assembly (contains items 1-7)	

* For use on 12" diameter softener tank only.

** For use on 14" diameter softener tank only.

PARTS ... BRINE VALVE HOUSING ASSEMBLY

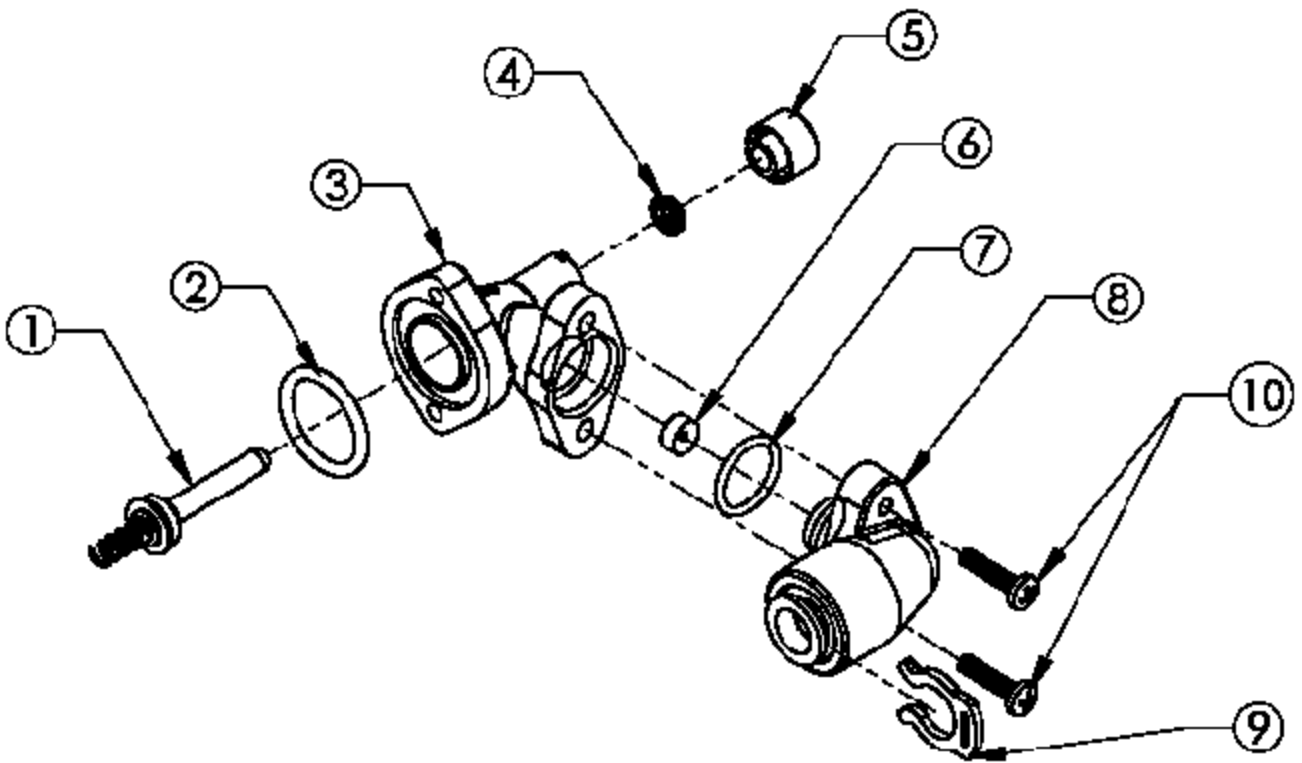

ITEM NO.	QTY.	PART NO.	DESCRIPTION
1	1	93820	Piston Assembly (includes O-ring & Spring)
2	1	90821	O-Ring
3	1	93260	Housing
4	1	93878	Quad Ring
5	1	93254	Quad Ring Retainer
6	1	90843	.5 gpm Flow Control
7	1	93806	O-Ring
8	1	93243-JG	Housing Cap Assembly (John Guest)
9	1	200199	3/8" Locking Clip
10	2	90818	Screw

PARTS ... BYPASS ASSEMBLY

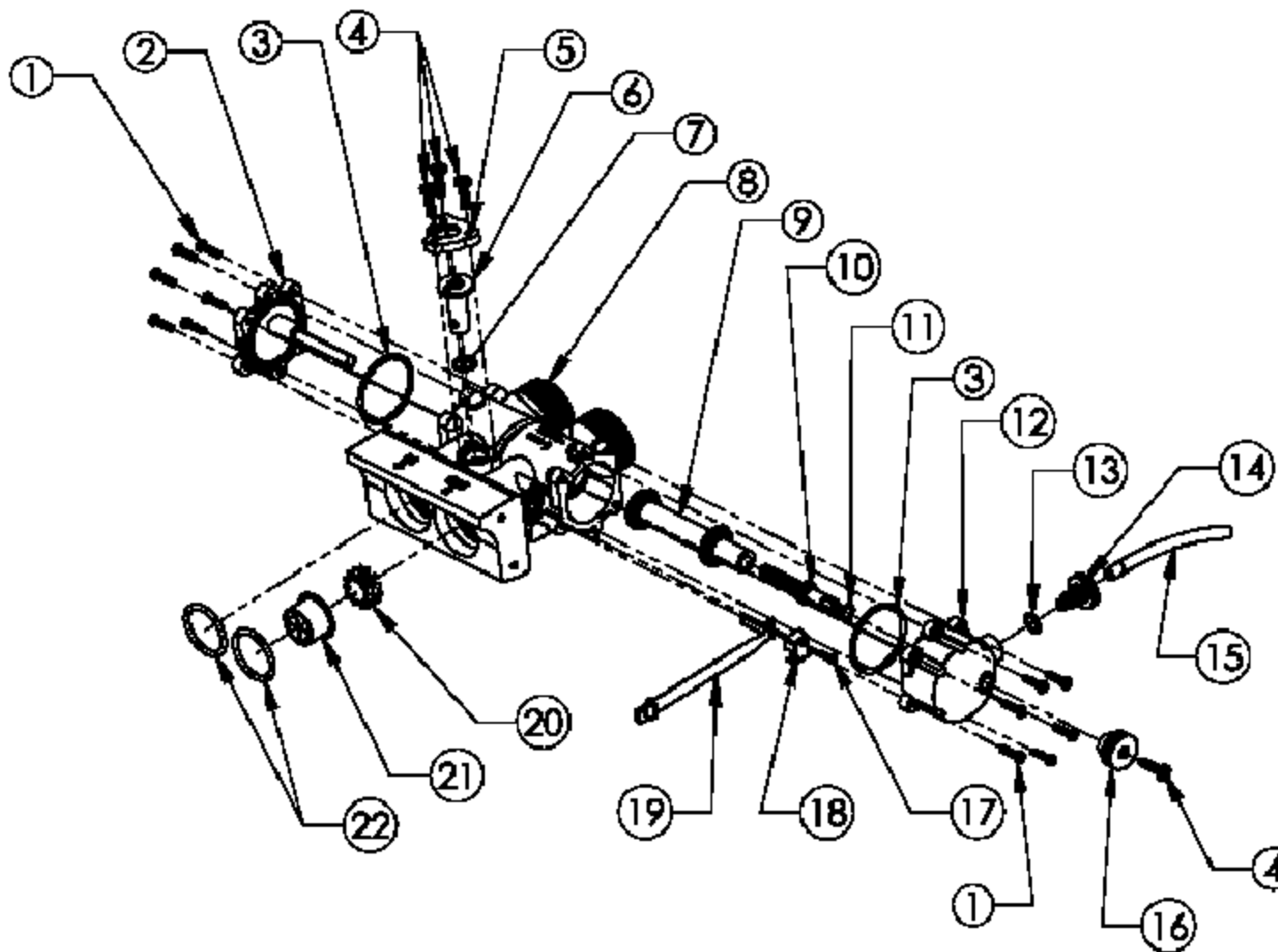

ITEM NO.	QTY.	PART NO.	DESCRIPTION	ITEM NO.	QTY.	PART NO.	DESCRIPTION
1	12	90807	Screw	12	1	90263	Bypass Endcap - right
2	1	90262	Bypass Endcap - left	13	2	90828	O-Ring
3	2	9380B	O-Ring	14	1	90228	Test Port Valve
4	6	90802	Screw	15	1	90812	Tubing 4.0"
5	1	90252	Cap - Blending Dial	16	1	90221	Bypass Piston Knob
6	1	90222	Blending Dial	17	1	90809	Screw
7	1	90827	O-Ring	18	1	90232	Turbine Sensor Cap
8	1	90246	Bypass Housing	19	1	93858	Turbine Sensor Assembly
9	1	90816	Bypass Piston Assembly	20	1	90622	Turbine Assembly
10	1	90218	Bypass Piston Drive Shaft	21	1	9322B	Flow Director
11	1	90803	O-Ring	22	2	9383B	O-Ring

PARTS ... BYPASS ASSEMBLY

90246 Bypass Housing: Makes the connection between the plumbing and Main Valve Body. Also, contains the "Hard Water" Blending Valve and Bypass Piston. The recommended seal for the 1-1/4" male inlet-outlet threads is the plastic Hook-up Nut (90251), O-ring (90837), and Copper Adapter (90254). Make sure the O-ring is between the Housing and Copper Adapter. The O-ring seal areas at the Main Valve Body inlet and outlet must be smooth and free of defects and debris, and lubricated with silicone grease before assembling. When attaching to the Main Valve Body, put the O-rings on the male bosses on the Valve Body and push the Bypass into place. A "snap" can be heard when the Bypass slides into place. When released, the Bypass should stay in place; if not, the O-rings may be "pinched." If the O-rings are pinched, replace with new ones. The Bypass comes pre-assembled with the Sensor housing and turbine axle. These are not field serviceable and if damaged, must be replaced with a new assembly. The Bypass Piston bore is to be smooth and, at the recessed areas, have a smooth transition (no sharp corners) to the seat areas.

90262 Bypass End Cap- Left: Seals the left Piston opening on the Housing (90246). The opening is sealed with an O-ring used as an axial or "face" seal. The O-ring sits in a groove in the End Cap. This groove must be free of defects such as pits or scratches and also free of debris. When assembling the End Cap to the Housing, care should be taken to make sure that the O-ring stays in the groove in the End Cap. If misaligned, the O-ring can become pinched and leak. Also, on the End Cap is the Piston Axle, a 1/4" square shaft that acts as a guide/slide and anti-turning mechanism for the Bypass Piston.

90263 Bypass End Cap- Right: Seals the right Piston opening on the Housing (90246). The opening is sealed with an O-ring used as an axial or "face" seal. The O-ring sits in a groove in the End Cap. This groove must be free of defects such as pits or scratches and also free of debris. When assembling the End Cap to the Housing, care should be taken to make sure that the O-ring stays in the groove in the End Cap. If misaligned, the O-ring can become pinched and leak. Also, on the End Cap is the guide/bushing for the Bypass Piston Drive Shaft. There is an O-ring seal at the opening for the Drive Shaft. This seal area must be free of defects such as pits or scratches and also free of debris.

90218 Bypass Piston Drive Shaft: The Drive Shaft has an acme thread which is used to move the Piston from "bypass" to "service" position. When operating the Bypass, to achieve either "service" or 'bypass', it is only necessary to turn the Handle (90221) until the Piston (90616) stops. Additional

pressure (torque) will not improve the seal. Once the Piston reaches the stop at either position, it can be backed off up to one half turn of the handle and still achieve a seal.

90616 Bypass Piston Assembly: The white teflon Hydro-slide O-ring covers should be free of defects such as indentations and cuts. The Piston should move freely into and out of the Bypass Housing without damaging the Hydro-slides. If the Hydro-slides catch, tear or crimp, the Housing should be replaced. Note: Some compression will occur when the Hydro-slides pass through the seal areas.

93858 Turbine Sensor Assembly: Picks up the magnetic field from the Turbine and relays it to the Controller. The three wire assembly connecting the "black wafer" Hall Effect Sensor to the Controller board must not be severely bent (folded over), cut, or broken. Care should be taken when putting the Sensor into the Sensor Housing. The "spring" flap below the Sensor must be gently bent over (on top of) the Sensor, and then the Sensor slide all the way into the Sensor Housing. The round hole of the Sensor mounting tab is then placed down over the mounting screw boss. The cap is then put in place and the mounting screw is installed. A slot is provided in the cap for the wire way to exit. The three-wire socket connector must be properly installed in the controller. Stops on the connector prevent improper (upside down) assembly. Do not force the connector past the stops.

90522 Turbine Assembly: The Turbine must have a 1/8" diameter Rare Earth magnet pressed into place adjacent to the axle opening. When assembled to the axle, the Turbine should spin freely. Do not use any lubricants. If the Turbine should become "jammed, clean and flush the Turbine and Bypass Valve.

90252 Blending Dial Cap: The Cap should be held in place by the three 1/2" screws and be in the proper orientation.

90222 Blending Valve: The valve permits the addition of "hard water" into the soft water outlet. It is closed when pointing toward the Main Valve Body and open when pointing toward the inlet side.

90226 Test Port Valve: The Test Port Valve is used to draw water samples for testing of treated water. Note: The Bypass must be in the "service" position to get an accurate sample. There are two types of seals on the Test Port. One seal is an O-ring which seals off the threaded area when the Valve is opened. The other seal is a compression seal between the Test Port Valve material and the Right End Cap material. If this seal is "overtightened", it can damage the sealing area on the End Cap causing a permanent leak.

PARTS ...3/4" I/O ADAPTER ASSEMBLY WITH BLENDING VALVE

Note: Parts 12, 13 and 15 are not field serviceable. Do not remove screws (#14)

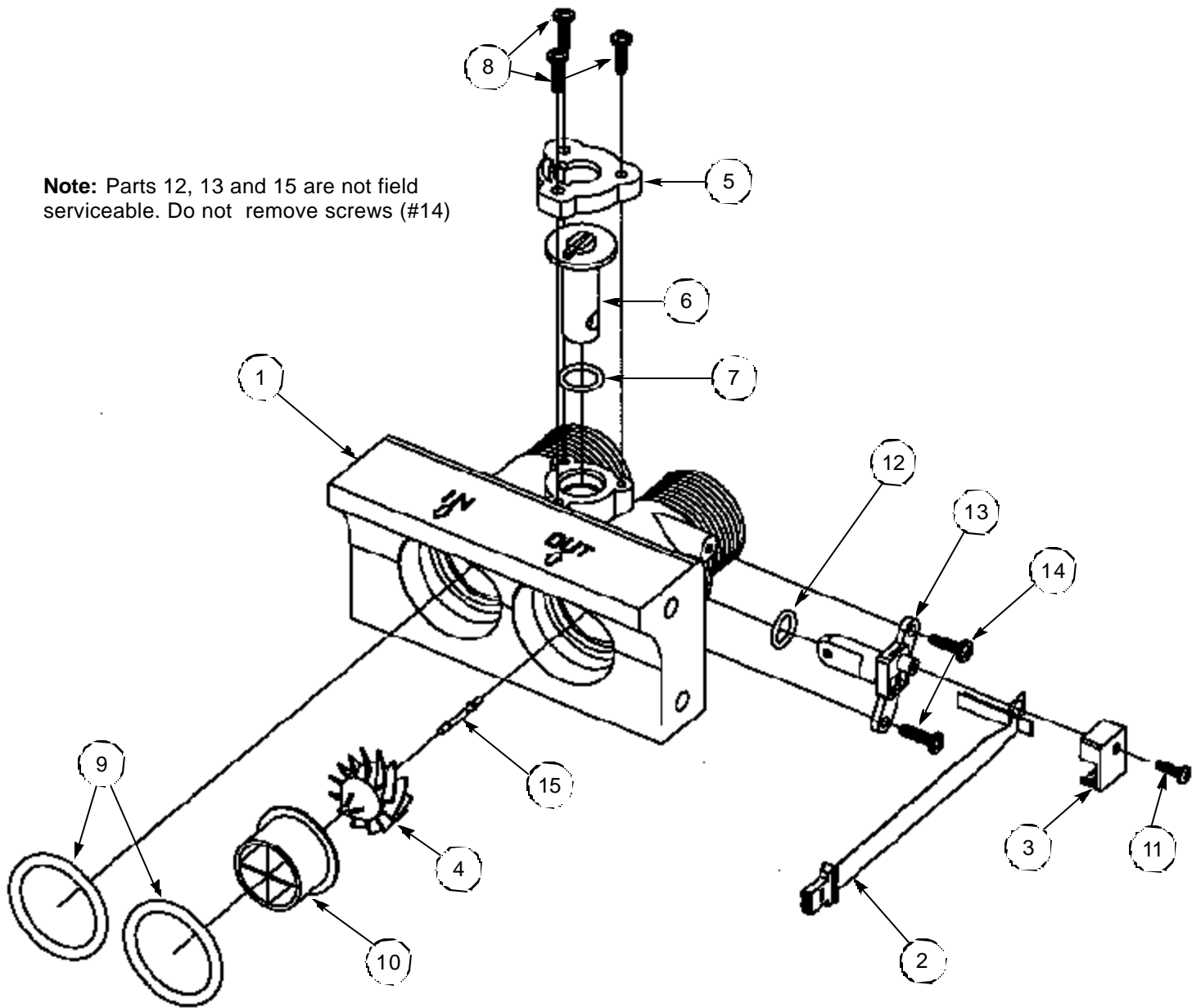

PART#	DESCRIPTION	QUANTITY	PART#	DESCRIPTION	QUANTITY		
1	93227	3/4" IO Adapter Assembly	1	11	90809	Sensor Cap Screw	1
2	93858	Turbine Sensor Assembly	1	12	90828	Turbine Sensor Housing O-ring	2
3	90232	Turbine Sensor Cap	1	13	93271	Turbine Sensor Housing	1
4	90522	Turbine Assembly	1	14	90802	Turbine Sensor Housing Screw	2
5	90252	Blending Dial Cap	1	15	90245	Turbine Axle	1
6	90222	Blending Dial	1		93521	3/4" IO Adapter Assembly (contains items 1-15)	
7	90827	"O" Ring	1				
8	90802	#6 X .5 Screw	3				
9	93838	"O" Ring	2				
10	93229	Flow Director	1				

PARTS ...1" I/O ADAPTER ASSEMBLY WITH BLENDING VALVE

Note: Parts 12, 13 and 15 are not field serviceable. Do not remove screws (#14)

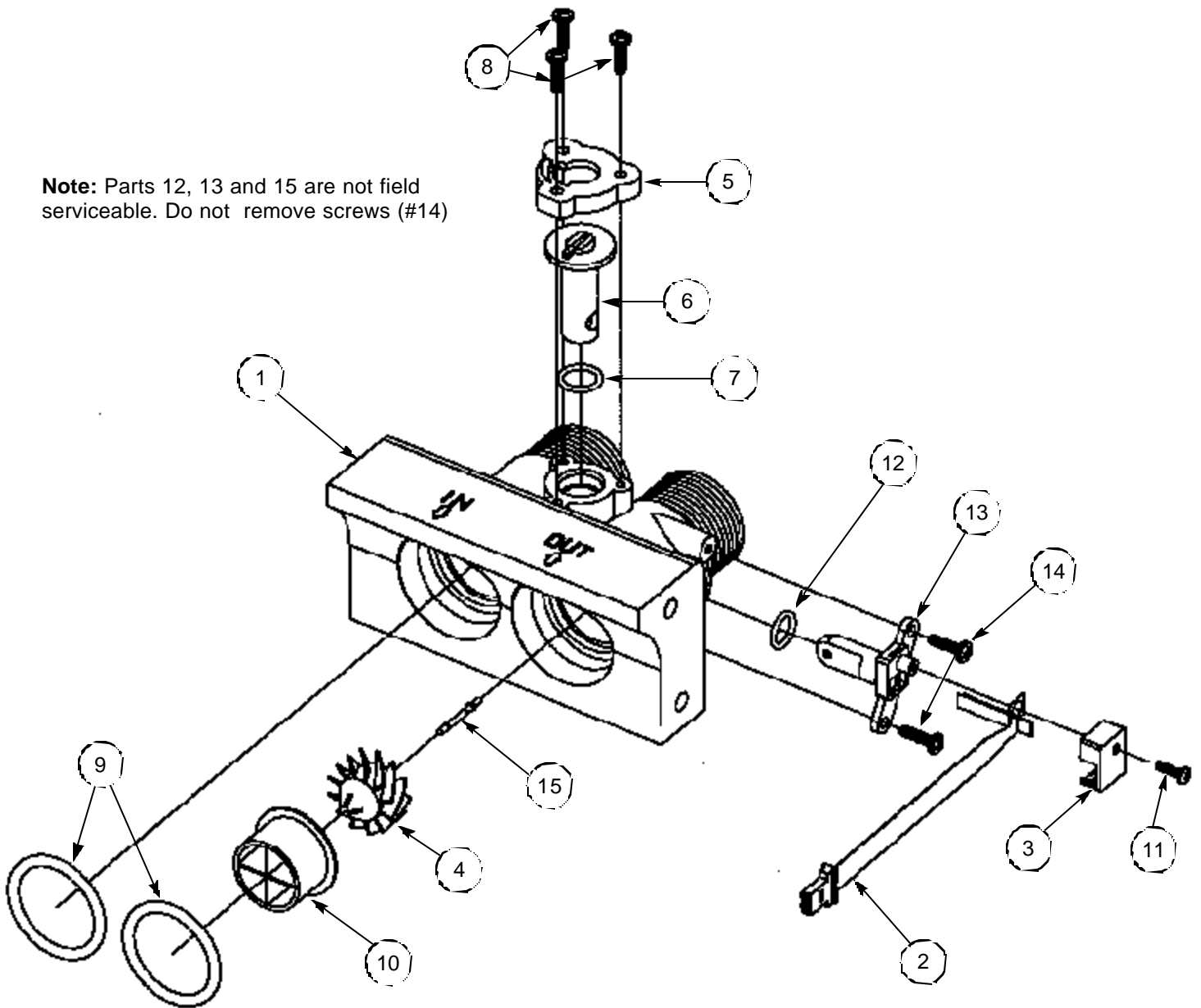

PART#	DESCRIPTION	QUANTITY	PART#	DESCRIPTION	QUANTITY		
1	93252	1" IO Adapter Assembly	1	11	90809	Sensor Cap Screw	1
2	93858	Turbine Sensor Assembly	1	12	90828	Turbine Sensor Housing O-ring	2
3	90232	Turbine Sensor Cap	1	13	93271	Turbine Sensor Housing	1
4	90522	Turbine Assembly	1	14	90802	Turbine Sensor Housing Screw	2
5	90252	Blending Dial Cap	1	15	90245	Turbine Axle	1
6	90222	Blending Dial	1		93521-1	1" IO Adapter Assembly (contains items 1-15)	
7	90827	"O" Ring	1				
8	90802	#6 X .5 Screw	3				
9	93838	"O" Ring	2				
10	93229	Flow Director	1				

PARTS ... DRIVE END CAP ASSEMBLY

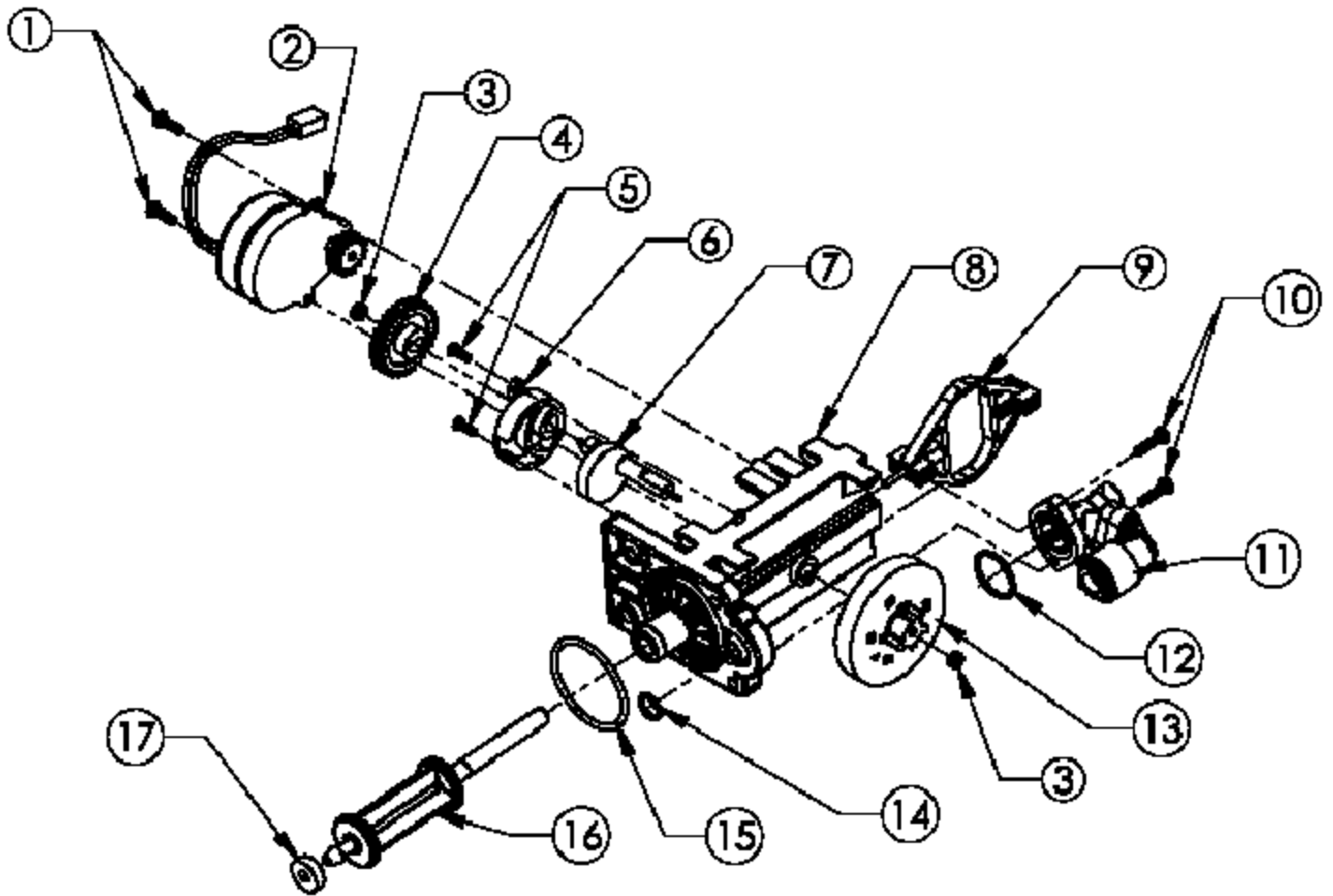

ITEM NO.	QTY.	PART NO.	DESCRIPTION	ITEM NO.	QTY.	PART NO.	DESCRIPTION
1	2	90802	Screw	10	2	90818	Screw
2	1	90217	Drive Motor	11	1	93801-JG	Brine Valve Housing Assembly
3	2	938B1	1/4" Hex Nut	12	1	90821	O-Ring
4	1	93238	Drive Gear	13	1	94508	Magnet Disk Assembly
5	2	90808	Screw	14	1	90828	O-Ring
6	1	93219	Piston Slide Cam Cover	15	1	93808	O-Ring
7	1	93217	Piston Slide Cam	16	1	93522	Drive Piston Assembly
8	1	935B3	Drive End Cap	17	1	93839	Drain Gasket
9	1	93218	Piston Slide				

PARTS ... DRIVE END CAP ASSEMBLY

95301T-JG Drive End Cap: Seals the two openings on the Main Valve Body. The larger diameter opening is sealed with an O-ring used as an axial or "face" seal. The O-ring sits in a groove in the End Cap. This groove must be free of defects such as pits or scratches and also free of debris. The smaller diameter seal is accomplished with an O-ring used as a radial seal. The O-ring should be placed on the male boss on the End Cap. When assembling the End Cap to the Valve Body, care should be taken to make sure the small O-ring is aligned with the opening in the Valve Body and that the large O-ring stays in the groove in the End Cap. If misaligned, the O-rings can become pinched and leak.

90217 Drive Motor: The Motor is held in place by two 1/2" screws. The screws should be "snug." The brass pinion gear on the Motor should engage the plastic Drive Gear. The wires should be securely fastened to the Control.

93216 Piston Slide: The Slide should move freely inside the End Cap Housing. The stainless steel threaded stud should be pointing toward the Valve Body.

93217 Piston Slide Cam: This is the "heart" of the drive system. There is a threaded stainless steel shaft that runs through the main drive axle. The Drive Gear is attached at the short end and the Magnet Disc at the other end. The Slide Cam is assembled inside of the Piston Slide (93216). This Cam Shaft should turn freely before the Motor is assembled.

93219 Piston Slide Cam Cover: The cover secures the Piston Slide Cam (93217) in place and acts as a bushing for the Cam Shaft.

93238 Drive Gear: The Drive Gear is assembled to the Slide Cam by means of a "keyed" opening which transfers the "torque" generated by the Motor to the rest of the drive system. If the drive system becomes jammed, this opening can become "rounded" causing the gear to turn, but not the Piston Slide Cam. If this occurs, clear the jam and replace the Drive Gear and Piston Slide Cam (93217).

93514-AJG Brine Valve Assembly: Attaches to the Drive End Cap with two 3/4" thread cutting screws and has one O-ring seal. The O-ring is used as a axial or face seal. The O-ring sits in a groove in the brine valve housing. The groove and the face seal must be free of defects such as pits and scratches or debris.

PARTS ... DRAIN END CAP ASSEMBLY

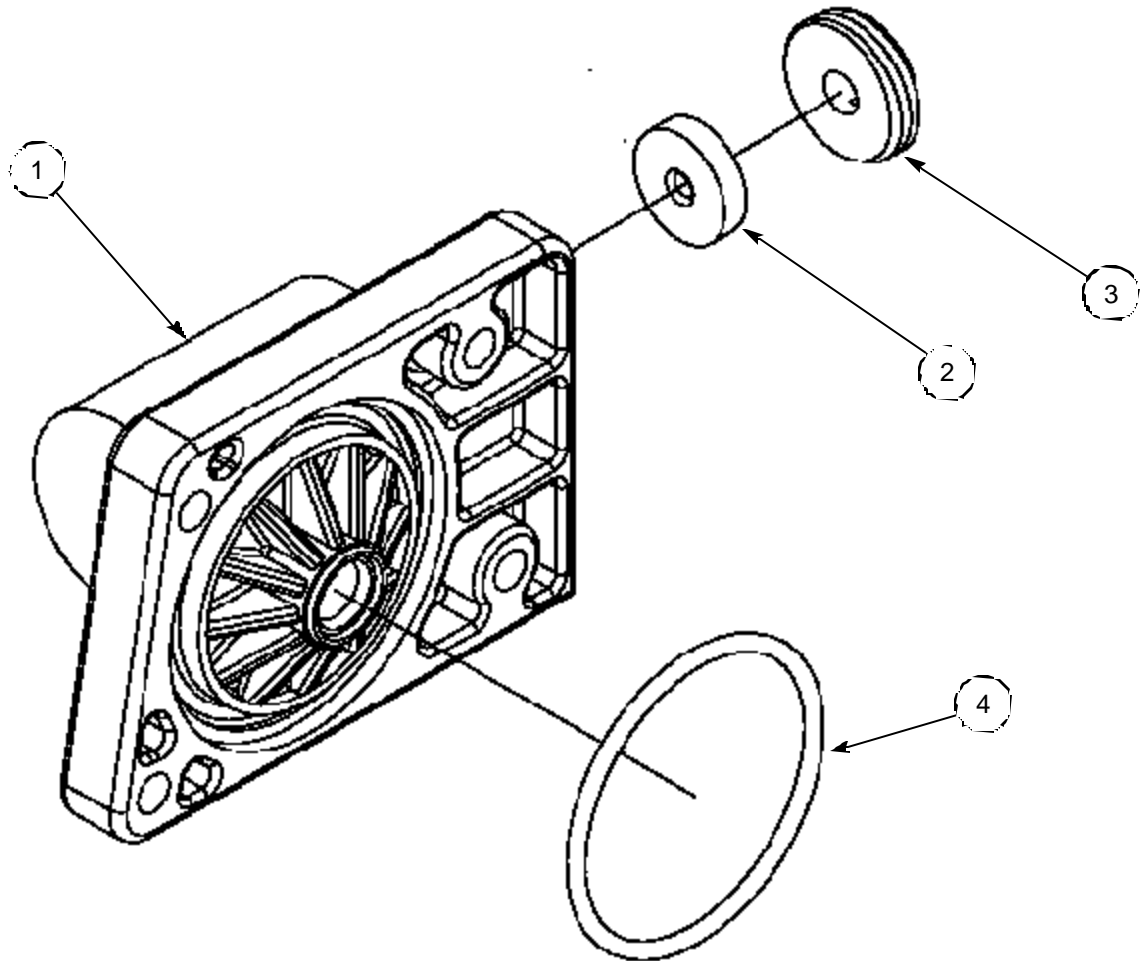

PART#	DESCRIPTION	QUANTITY
1 90268	Drain End Cap	1
2 H2086 - 1.2*	Drain Line Flow Control	1
H2086 - 2.0*		
H2086 - 2.4*		
H2086 - 3.0*		
H2086 - 4.0*		
H2086 - 5.0*		
H2086 - 7.0*		
3 90267	Retainer	1
4 93808	End Cap O-ring	1
90614	Drain End Cap Assembly	

*The number shown after the drain Line Flow Control Button part number indicates the back wash flow rate in gpm.

PARTS ... SAFETY SHUTOFF ASSEMBLY

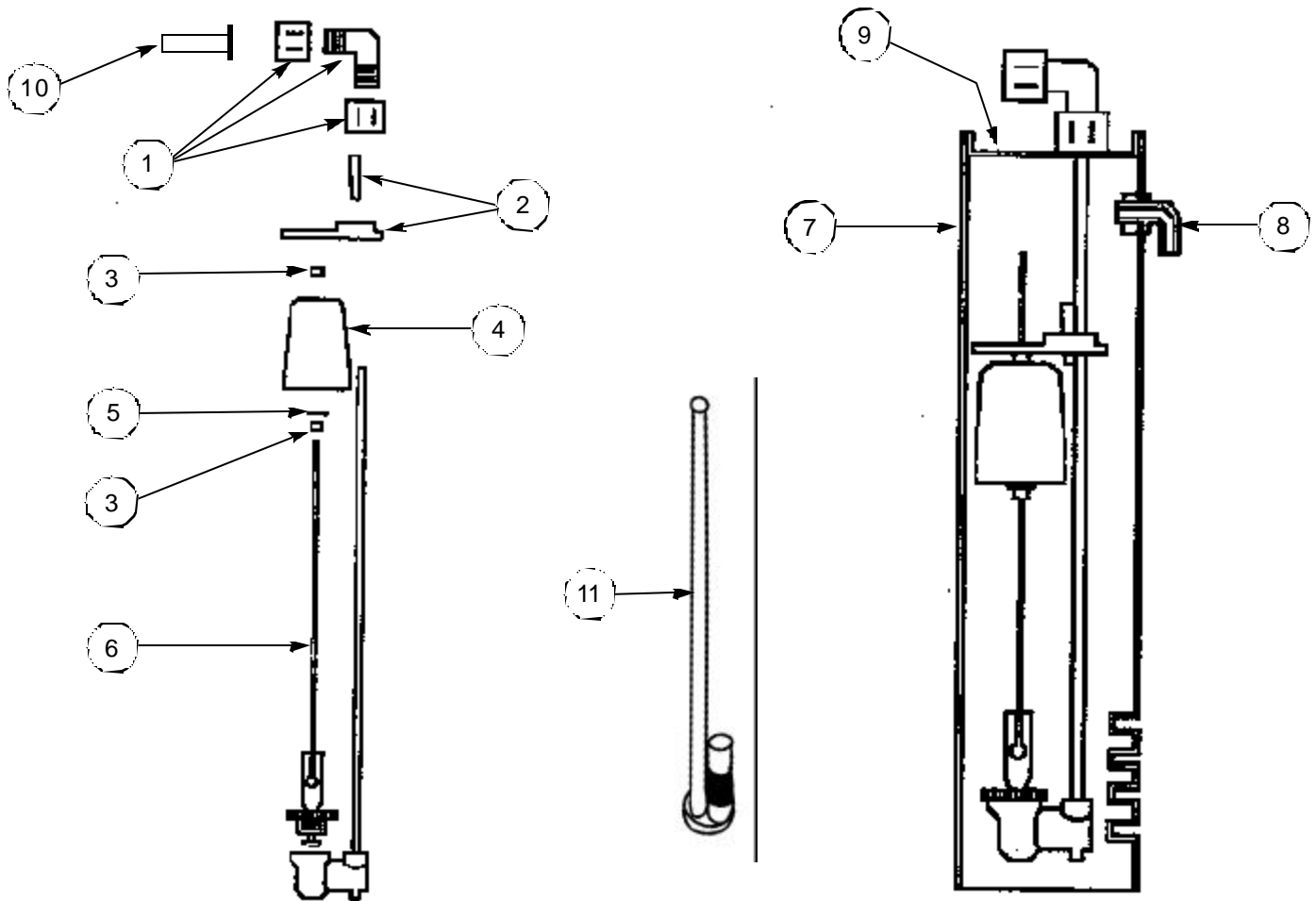

PART#	DESCRIPTION	QUANTITY
1 51366	Air Check Elbow Assembly	1
2 H7041	Guide and Lock Set	1
3 H7039	Float Grommet	2
4 H7040	Bell Float	1
5 H7042	Float Washer	1
6 H7038-01	Float Rod	1
7 90102	3.5 X 26.5 Brine Well	1
8 C0700	2 pc. Overflow Fitting	1
9 CO600	Brine Well Cap	1
10 201120	3/8" Nylon Insert	1
11 93882-25.75	Air Check Draw Tube (standard brine tank) 18" X 33"	1
93811-26.5	Air Check / Brine Well Assembly	
93811-20.0 IF	Air Check / Brine Well Assembly, Iron Filter Only	

Brine Valve Elbow Installation Instructions

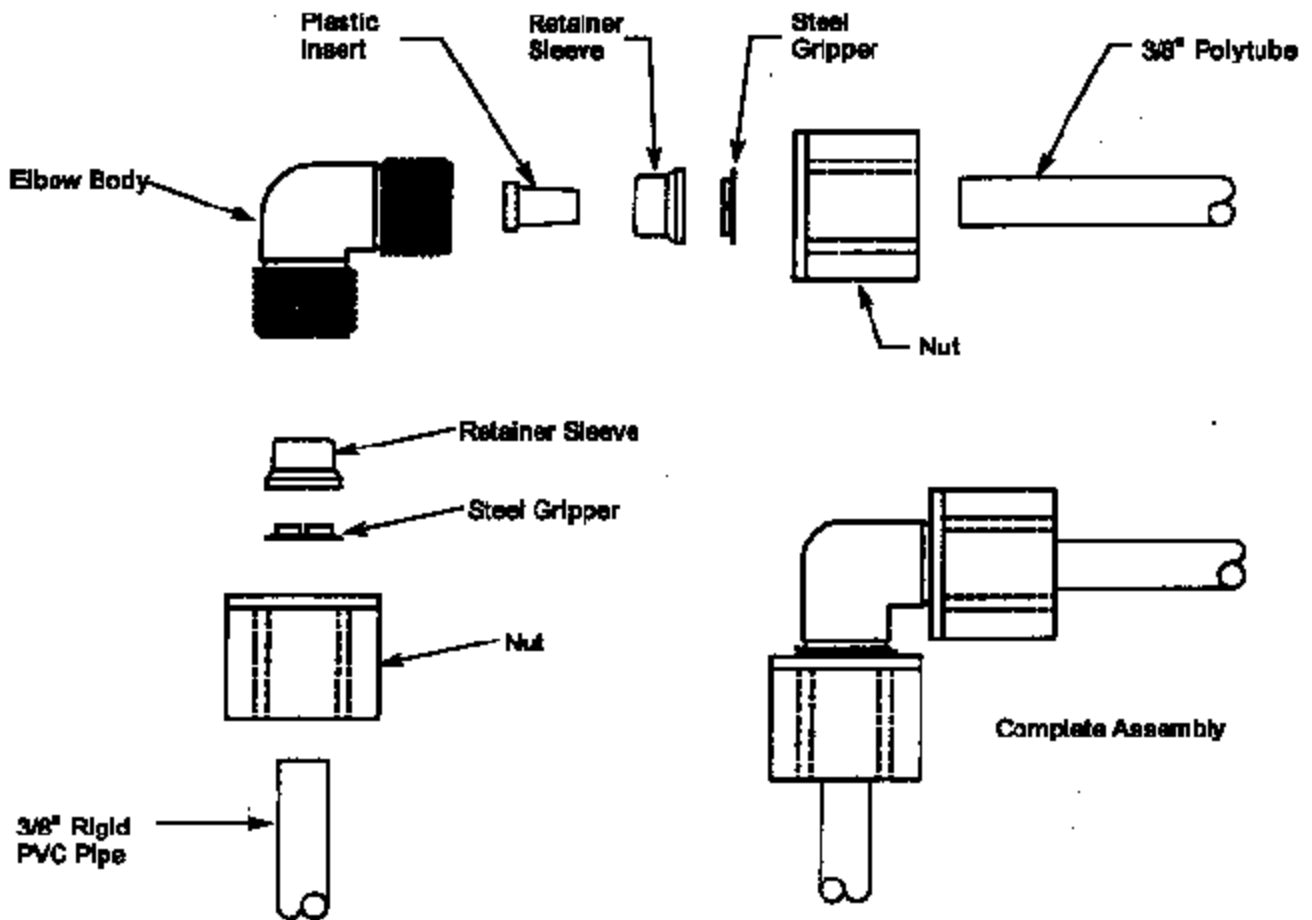

The nut, gripper and retainer sleeve are a 3 piece assembly that can come apart if removed from the elbow body. Parts must be re-assembled exactly as shown to function properly.

When connecting the 3/8" polytube, it is first necessary to assemble the nut, gripper and retainer sleeve on the tubing before inserting the plastic insert, Screw the nut on the elbow body. With a wrench, tighten nut securely to create a pressure tight connection.

Warranty

HAGUE Hydro-Clean® 10 Year Limited Residential Warranty

This warranty is issued to the original owner only and is not transferable to subsequent owners.

TO PLACE THE EQUIPMENT UNDER WARRANTY, THE WARRANTY REGISTRATION CARD MUST BE COMPLETED AND RETURNED BY THE OWNER TO WM. R. HAGUE, INC. WITHIN 30 DAYS OF INSTALLATION.

Coverage

This warranty covers the Hague Equipment delivered to the original owner, when the system is purchased for personal, family or household use. It is intended to cover defects occurring in workmanship or materials or both.

Warrantor's Performance and Length of Warranty

Wm. R. Hague, Inc. warrants that upon receipt from the original owner of The Hague Equipment Mineral Tank, Brine Tank, found to be defective in material or workmanship, Hague will replace said part(s) at no charge for those parts for 5 YEARS from date of installation. And thereafter, will replace said parts upon payment of the following percentages of the then current list price: 6th through 10th year - 50% of current price list.

Wm. R. Hague, Inc. further warrants that upon receipt from the original owner of The Hague Equipment Valve and/or Power System Components (i.e. complete valve controller) found to be defective in material or workmanship, Hague will replace said part(s), at no charge for those parts, for 3 YEARS from date of installation.

Defective parts to be replaced must be returned, along with the equipment serial number and date of original installation, to Wm. R. Hague, Inc. PREPAID and will be returned to the original owner FREIGHT COLLECT.

THERE ARE NO WARRANTIES OTHER THAN THOSE DESCRIBED IN THIS WARRANTY INSTRUMENT. THIS WARRANTY DOES NOT COVER INCIDENTAL, CONSEQUENTIAL OR SECONDARY DAMAGES.

ANY IMPLIED WARRANTIES ON THE PRODUCT DESCRIBED IN THIS WARRANTY WILL NOT BE EFFECTIVE AFTER THE EXPIRATION OF THIS WARRANTY.

This warranty does not cover any labor or service call costs incurred with respect to the removal and replacement of any defective part(s). Wm. R. Hague, Inc. will not be liable for, nor will it pay any labor or service call charges incurred or expended with respect to this warranty.

In the event the water supply being processed through this product contains bacterial iron, algae, sulphur, tannins, organic matter or other unusual substances, then unless the system is represented as being capable of handling these substances in the system specifications, other special treatment of the water supply must be used to remove these substances before they enter this product. Otherwise, Wm. R. Hague, Inc. shall have no obligation to supply replacement parts under this warranty.

This warranty does not cover damage to a part(s) of the system from causes such as fire, accidents, freezing, or unreasonable use, abuse or neglect by the original owner.

This warranty does not cover damage to part(s) of the system resulting from improper installation. All plumbing and electrical connections should be made in accordance with the installation instructions provided with the system. The warranty does not cover damage resulting from use with inadequate or defective plumbing, inadequate or defective water supply or pressure; inadequate or defective house wiring; improper voltage, electrical service or electrical connections; or violation of applicable building, plumbing, or electrical codes, ordinances or regulations.

This warranty is null and void unless the Hague Hydro-Clean® System was purchased at retail from an independent authorized Hague dealer and installed by same.

Some states do not allow limitations on how long an implied warranty lasts or the exclusion or limitation of incidental or consequential damages, so the above limitations or exclusion may not apply to you. This warranty gives you specific legal rights and you may also have other rights which vary from state to state.

For Owner's Reference

Equipment Serial No.

Installation Date

Independent Dealer Name

Installer's Signature



©2000 **HYDRO-CLEAN III** P.O. Box 298, Groveport, OH 43125

LITHO USA Form #53120 RV0802HQWI